

NorvaNivel

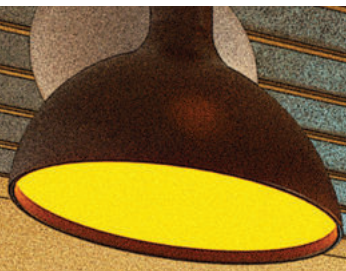
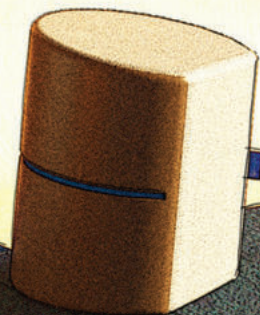



Table of Contents

| | |
|---|-----|
| SECTION 1 Our Story | 02 |
| SECTION 2 Products | 14 |
| SECTION 3 Spaces | 44 |
| SECTION 4 Materials, Index, and Height Chart | 112 |

Bound only by the perimeters of our imagination and grounded in our own children's future, our story begins in Australia and continues globally with a sole mission: to redefine the environment in which we learn. With curiosity at our core and an endless passion for learning ourselves, we have been committed from the start to creating a movement that propels learning forward for all. Crafted designs intended to inspire, our products create opportunities for limitless discovery and connections.



SEE OUR FULL STORY

As you begin this journey with us, we invite you to become a part of our story.

Our spaces are curated to bring learning to life, connect knowledge to experience, and transform the lives of not one, but every individual.

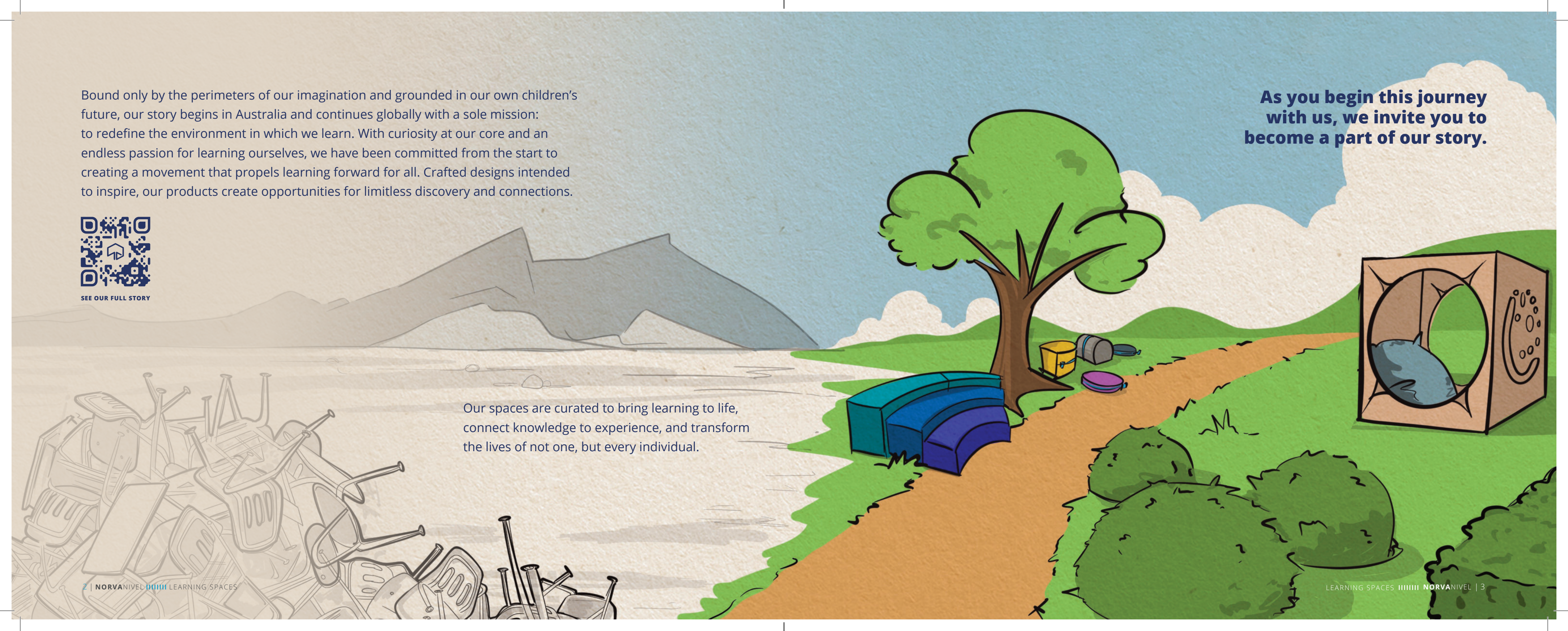



**Together
we will open
our minds,
share our
experiences,
and be
fearless.**

*And when we arrive
at the conclusion, we will leave
armed to provoke and embrace
positive change and action,
leaving a legacy of excellence
for generations to come.*

Don't Desk Me In

As you explore the world of NorvaNivel, you will discover the stories of those courageous and bold enough to share.

These stories speak to the big voices and the little voices, and they embrace our overwhelming desire for freedom of thought, our human right to be unique individuals, and our need for connection and creativity.

These are the stories that guide us, inspire us, and challenge us.

They help us understand how we can design better, learn better, and be better. The collection, and sharing of these stories, continues beyond the pages of this book...

The most important thing for adults to know about kids is it's important that they feel safe.

— SHYANNE





Collaboration
is at the heart
of what we do,
and collaborative,
engaging
learning
environments
are all we do.

Working Together

We are masters of progressive learning space design through the lens of education, innovation, and function. We engage all stakeholders in the process of creating imaginative and innovative learning spaces that align to the needs of learners. By utilizing our custom live design and professional learning workshops, led by our team of out-of-this-world designers, architects, educators and administrators, our mission remains to create high impact learning environments.

From Early Learning to Higher Ed, the combination of our spaces and intentional products allow us a unique toolkit for the reimaging of education. We partner with the souls who share our vision and continually seek to collaborate with those who also want to impact education — and change the world.

Our Design Philosophy

We believe that there is no one-size-fits-all approach to learning. We know that education can, in fact, **change** the trajectory of a person's life, and we live to be a part of it.

We **value** the immense impact that intentionally designed products and thoughtfully curated spaces can make in fostering learner engagement and agency. When designed with functional intent, these spaces can elevate the learning and engage the learner.

We believe that human-centered design thinking is our key to connecting our spaces with our teaching, our learning, and our culture in a tangible and meaningful way.

We continually seek opportunities to purposefully set the conditions for mastery of skills and connections needed in tomorrow's world through functional and inspired design.

Like our spaces, we continually adapt to the ever-changing world around us through our relentless commitment to the pursuit of innovation.

We design only
for education
and manufacture
every product
we sell.

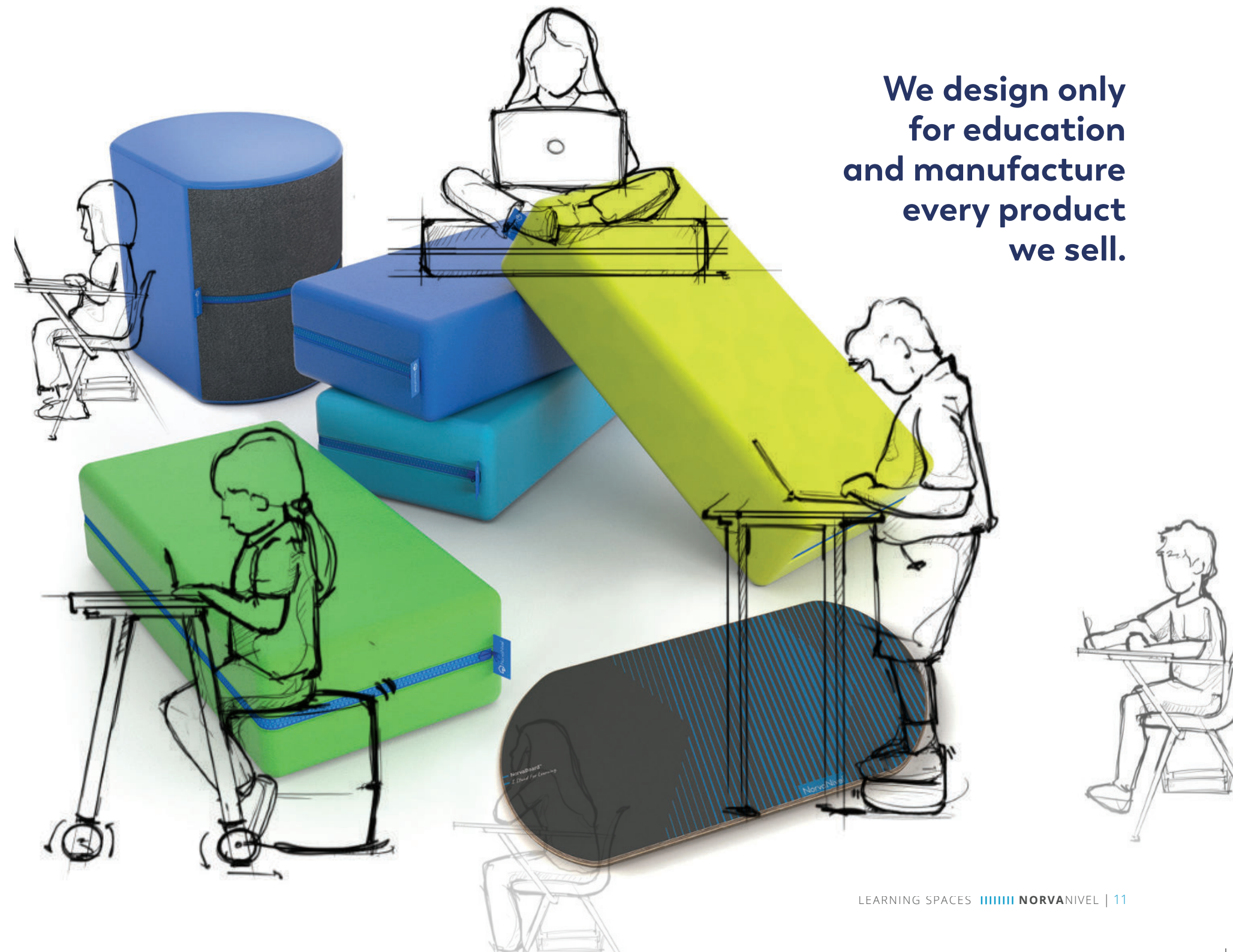

Our designs are set to challenge conventions with the intent of awakening our senses.

— AVRON LEVIN FOUNDER AND CREATIVE DIRECTOR, NORVANIVEL



Conclave™

We create products that speak to choice...

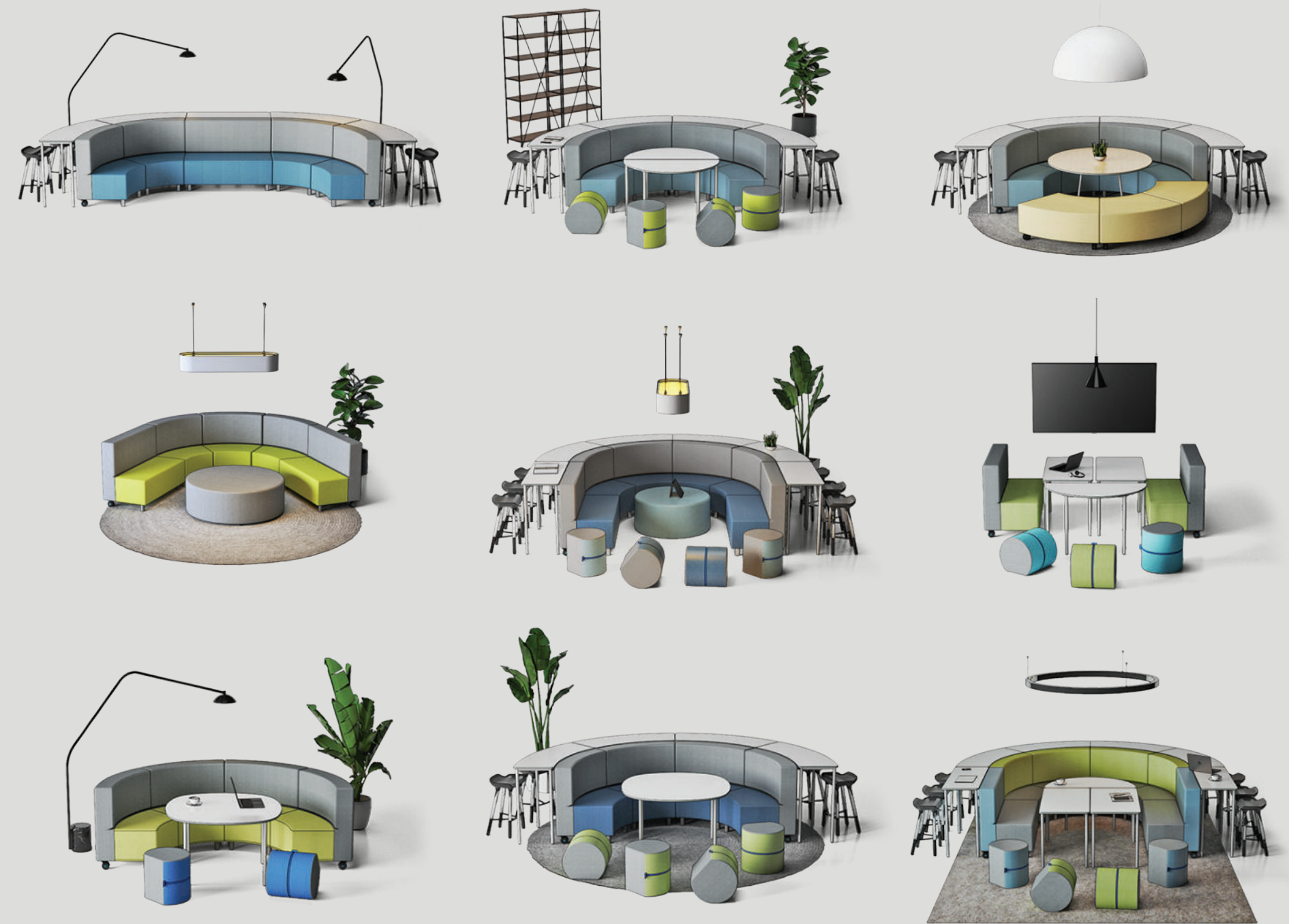

SunshineOnACloudieDay™

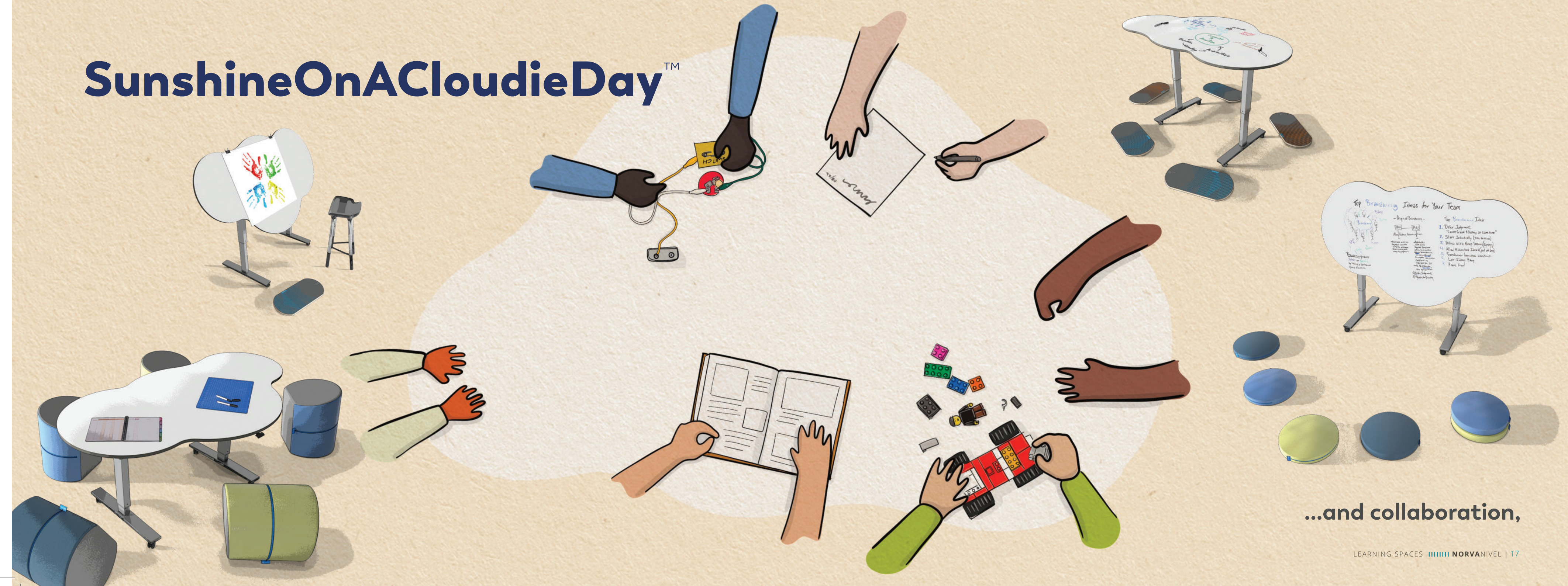

...and collaboration,

RockerOtt.10™

encourage movement and adaptability...

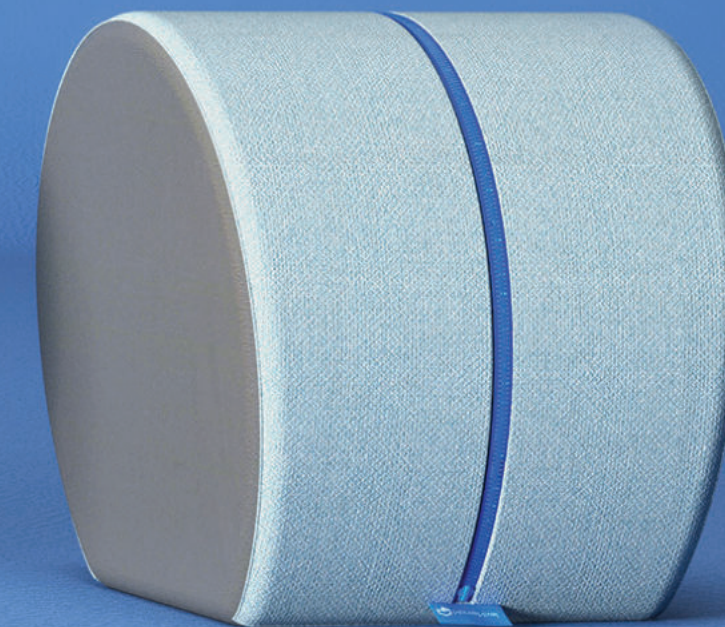
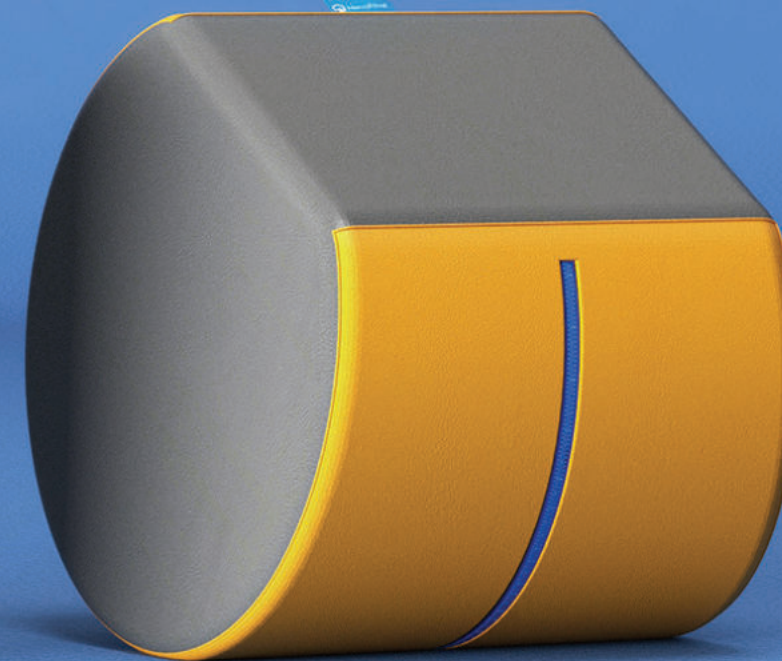
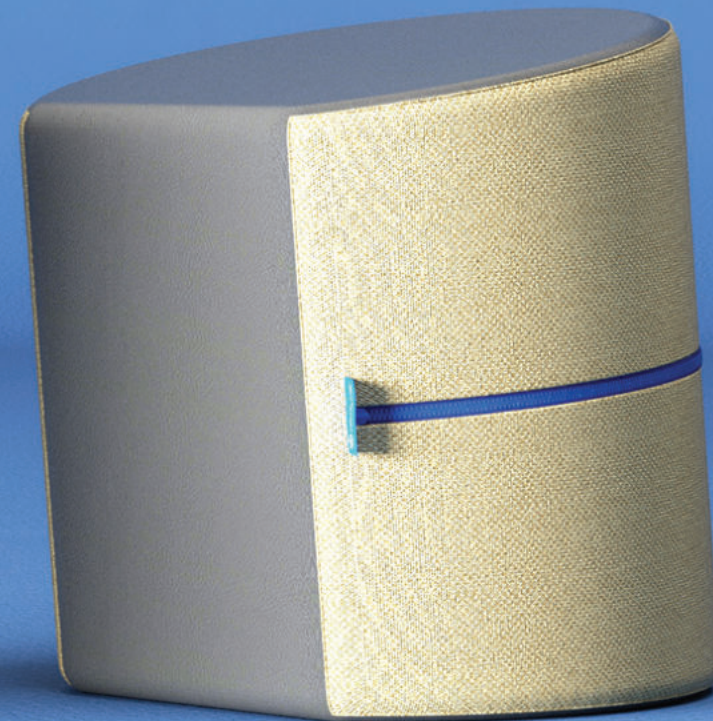

NorvaBoard™



...improve our
cognitive function

Collab Collective



and are infinitely reconfigurable.

Products that consider all of our senses

GrassyOtt™

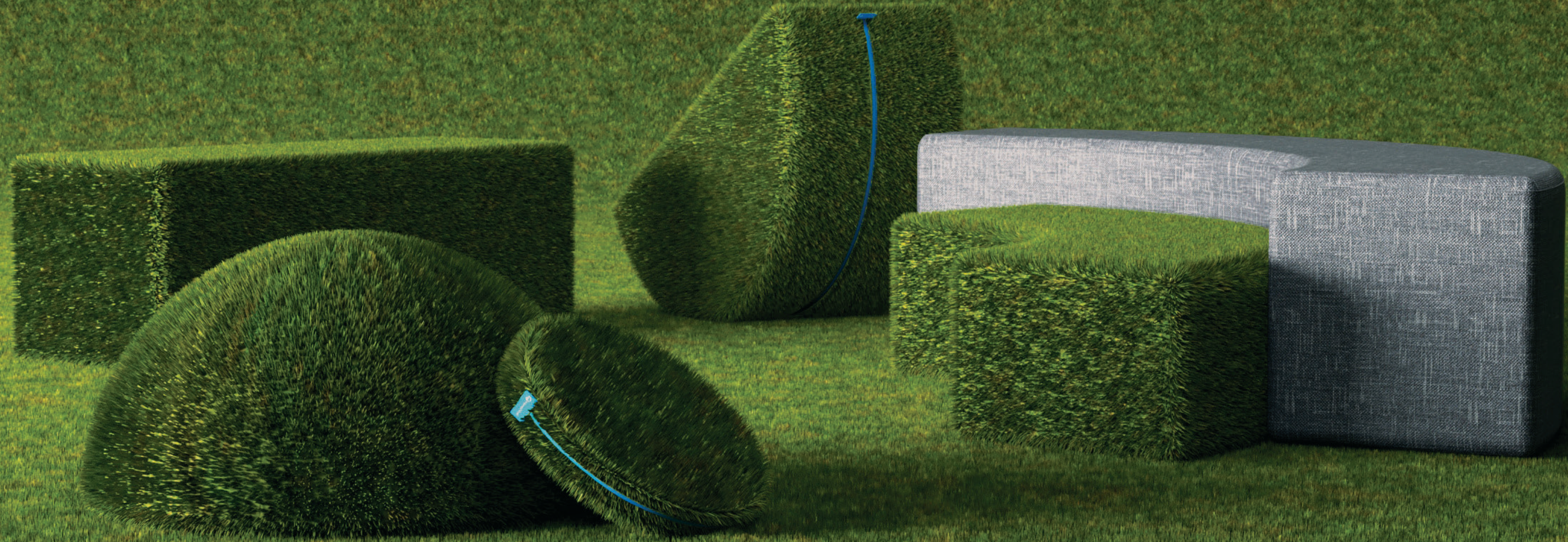

TacTiles™

that are designed to encourage learning by experience.

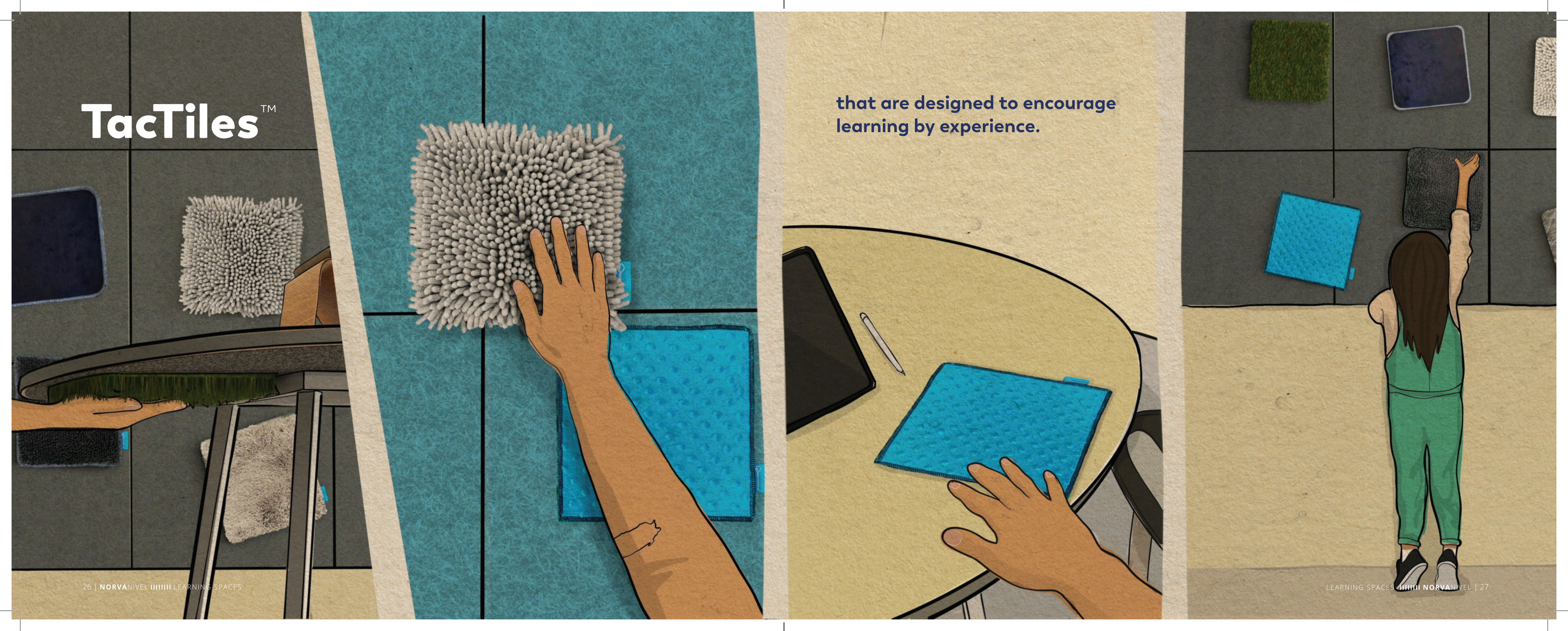

Products that ignite
our creativity and
natural curiosities



1 or more players



genga™

Contents: Large and Small NorvaNivel Genga™ Blocks

 **WARNING:**
The contents are extremely agile.

**Areas of
Recommended Use:**
Everywhere

Instructions:
User specified design.
Suggested formats: cave,
community gathering,
presentation, individual work,
Have been used as work
surfaces and seating solutions!
**Limited only by your imagination*

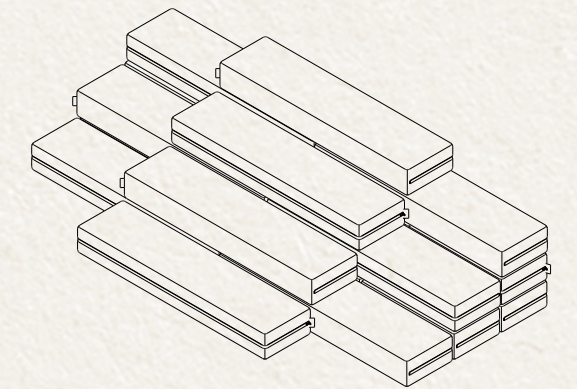
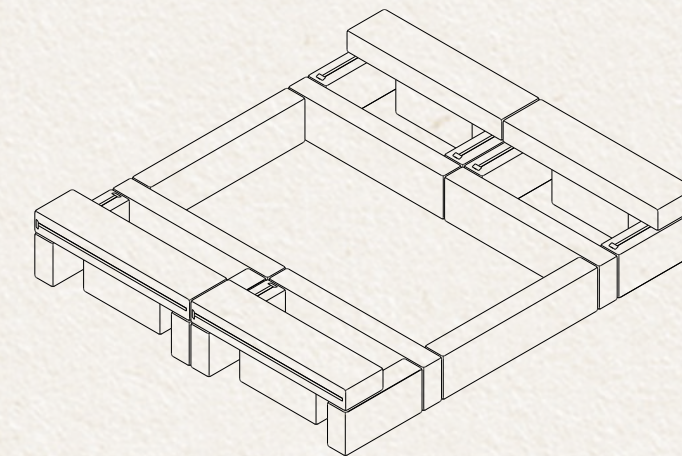

IncuPod™

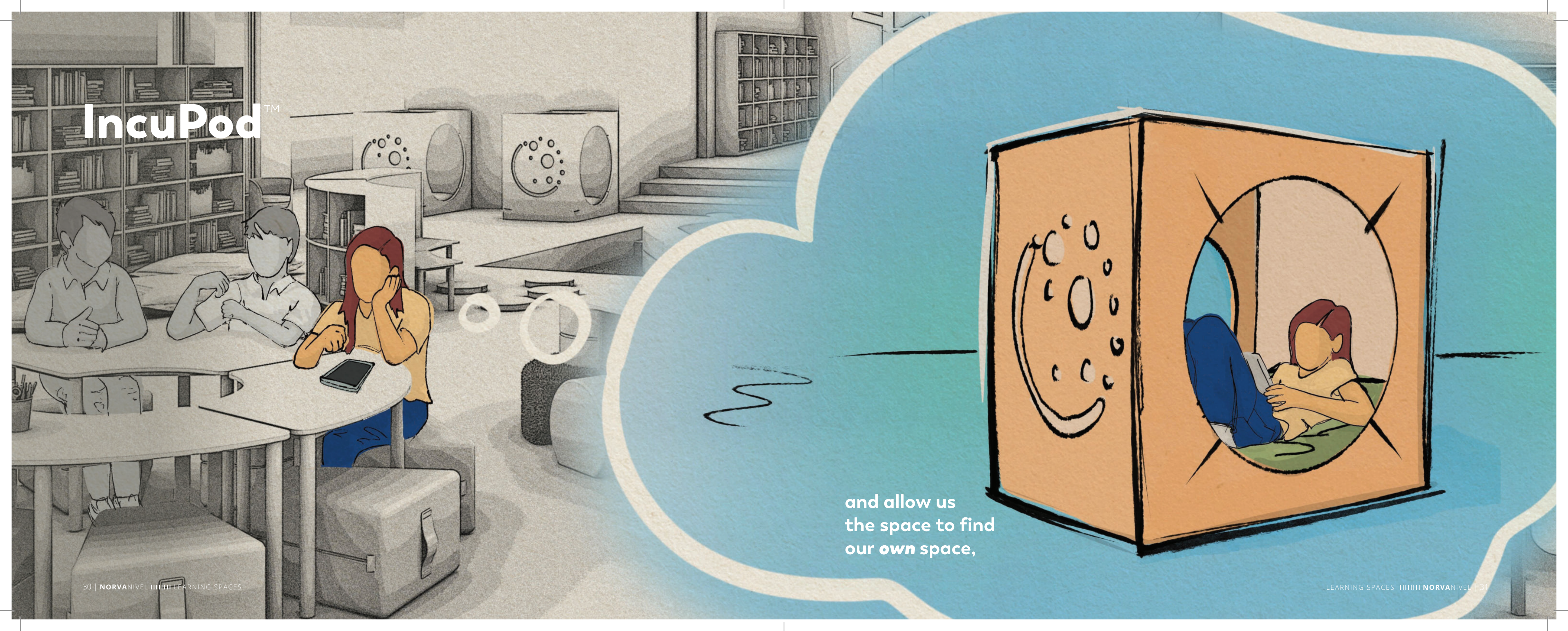

and allow us
the space to find
our **own** space,

Irregular Shape Tables

opening up limitless
opportunities to connect,

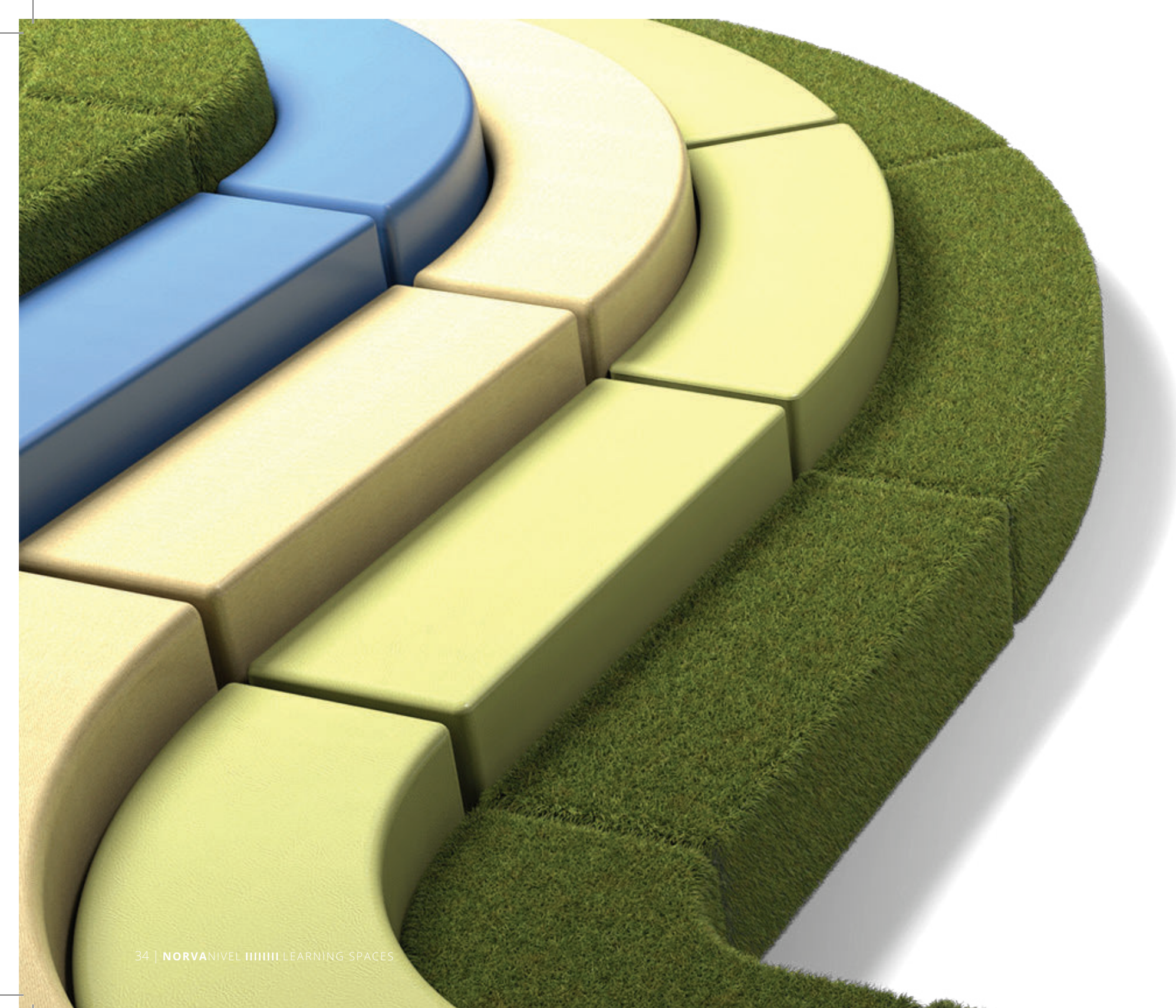

Amphi™
disconnect and reconnect,

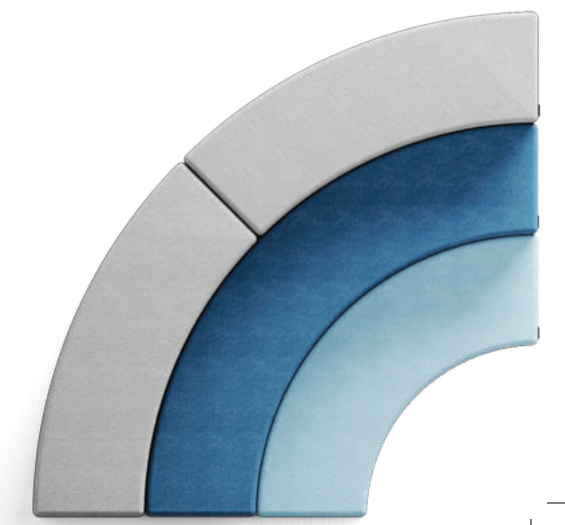
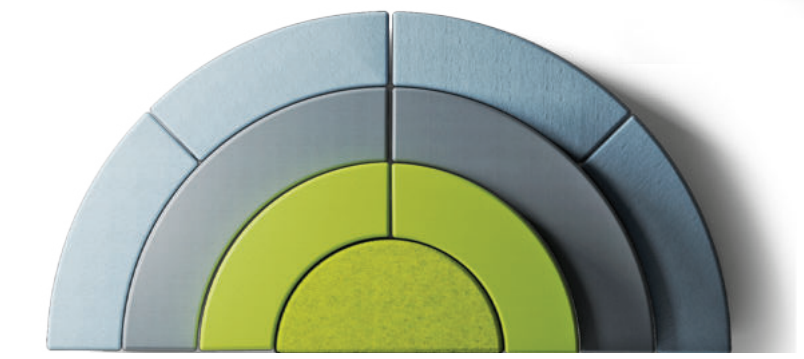
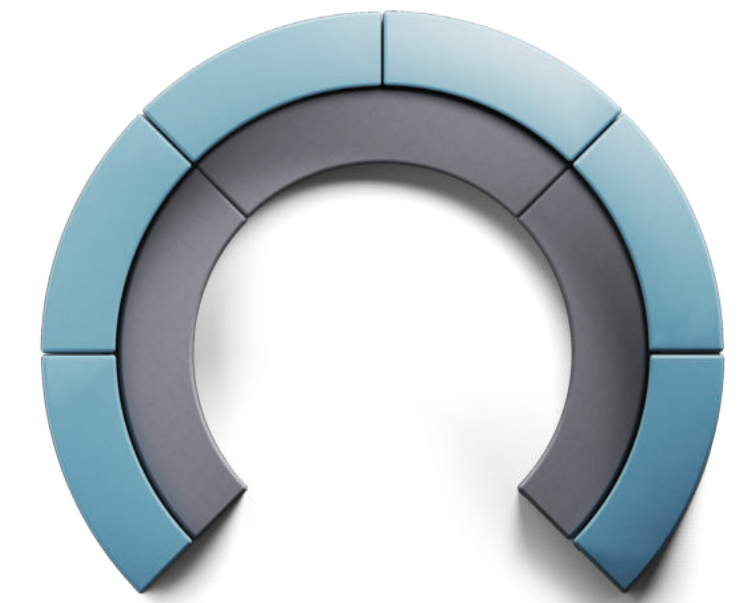
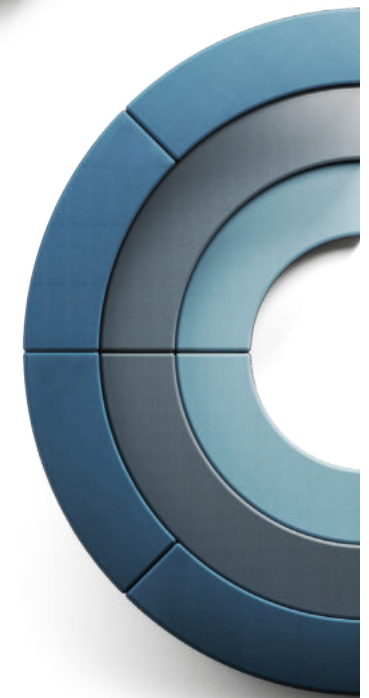

WorkPad™ Caddy

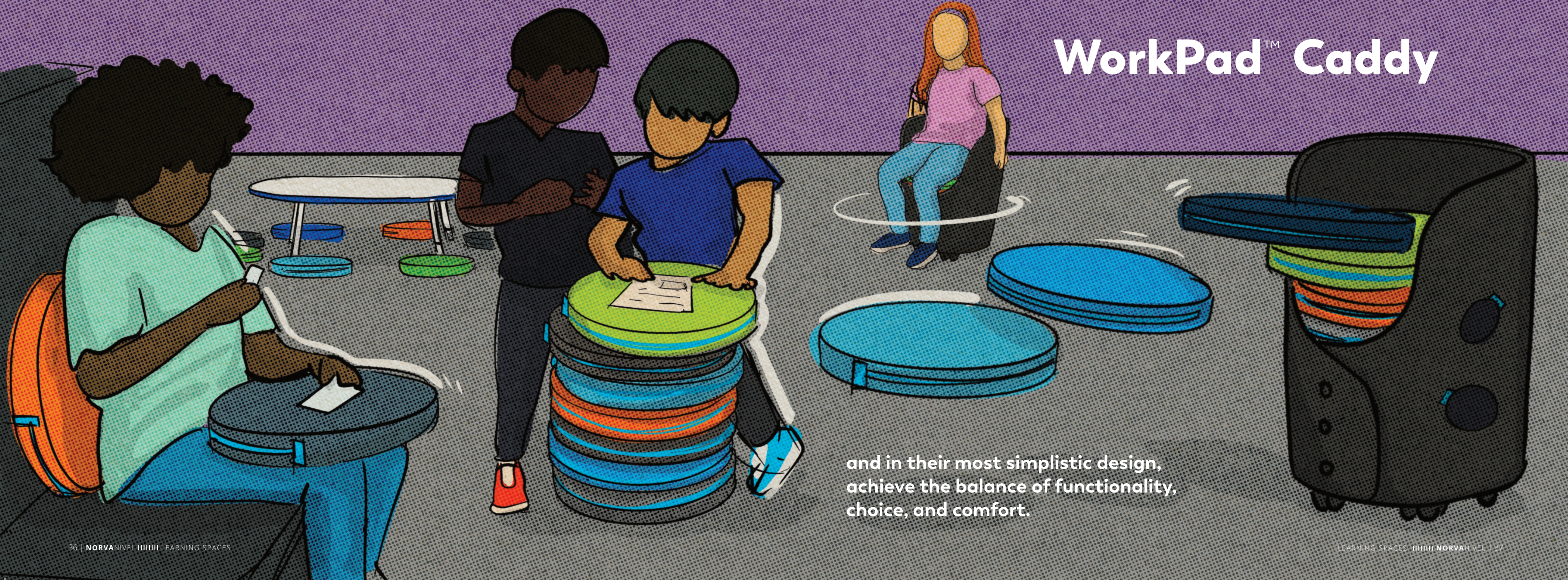

and in their most simplistic design,
achieve the balance of functionality,
choice, and comfort.

In ways both imagined and unexpected,

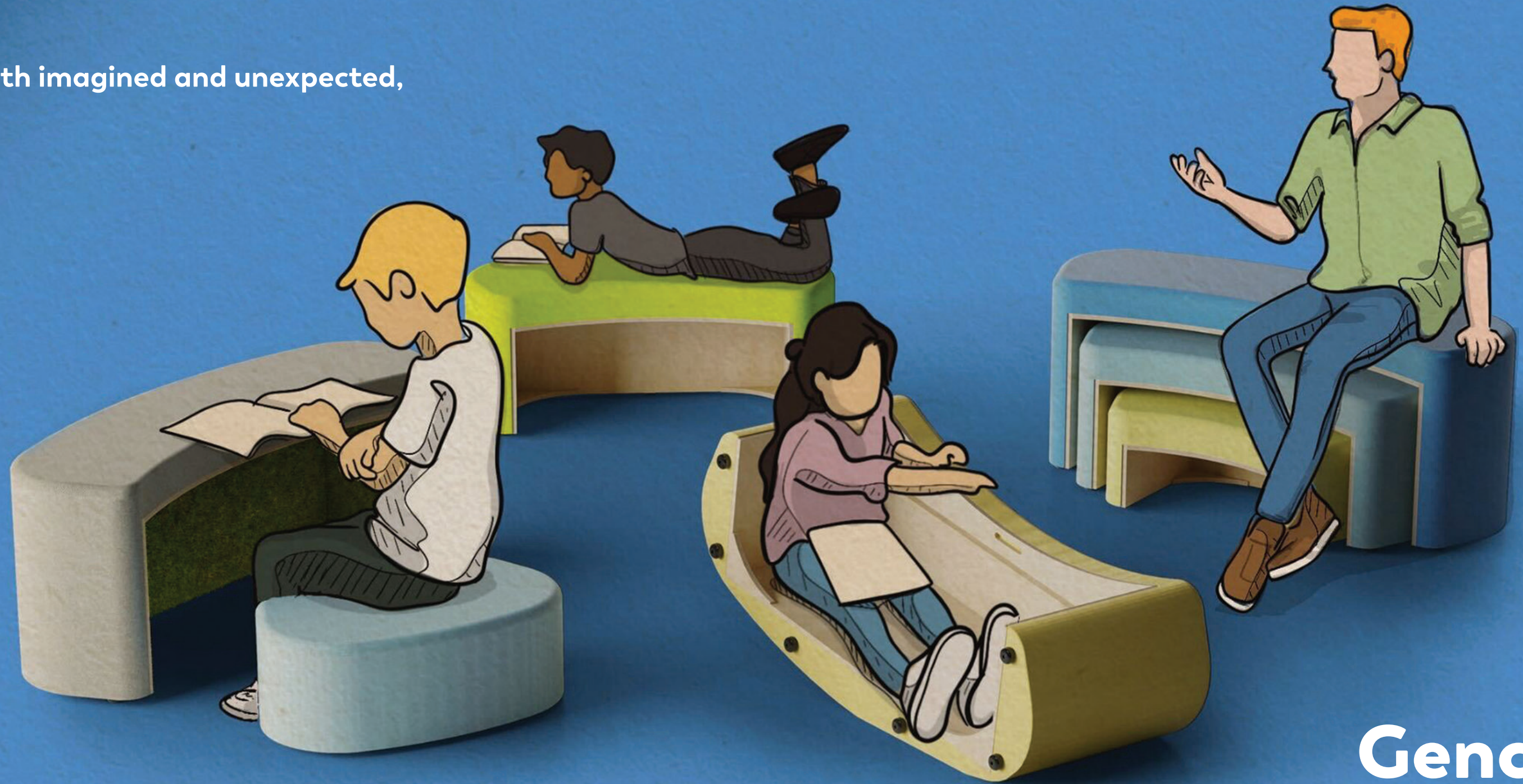

Genci™

Storage

ensuring organization and accessibility to resources in all spaces and places.



Our Learning Space Philosophy

From early learning to adulthood, we seek to create spaces that consider a synchronous impact, to both the learner and academic and pedagogical goals, facilitating the movement towards a future-ready education system.

Spaces curated to promote a strong culture of learning and a strong sense of self.



Incubating the growth of unique skills and interests, while continually striving to achieve equity and diversity, we challenge the concept of equality.

Our spaces encourage guided choice through their intentional adaptability.

Our products open up opportunities to engage in genuine inquiry, allowing for that connection between experience, knowledge, and environment.

Ultimately, we strive to create spaces designed for humans that consider social and emotional growth as an integral component to both personal and academic success.

It is better than you would expect from the individual parts because the way they combine adds a different quality.

— ARISTOTLE

Classrooms

The classroom environment is on the cusp of undergoing the greatest transformation. Unbounded by the traditional physical space, the classroom of today is now a space for creative, collaborative activities, stimulating discussion and supporting varied teaching and learning styles.

We provide spaces that consider comfort and safety, while facilitating quick and relevant adaptability to a multi-faceted and evolving curriculum, creating opportunities for dynamic transitions.

Our opportunity and challenge today is to create classrooms designed specifically to facilitate the growth of future-ready skills, and the varied unique needs of today's learners.

Pre-K Classroom

Here's to the creative carpet timers, the crayon collectors, the line leaders, and the exponential energy providers.

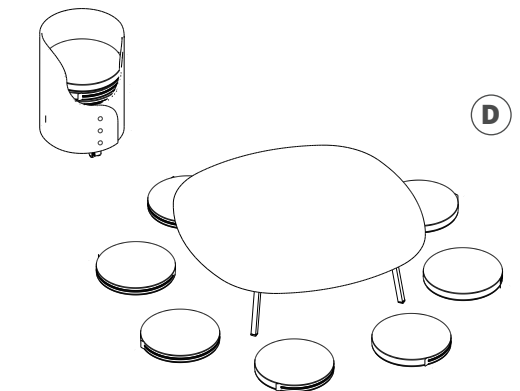
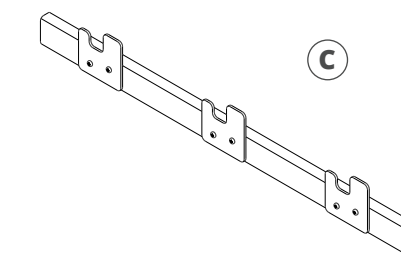
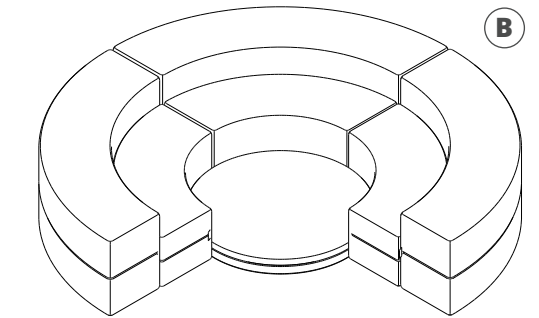
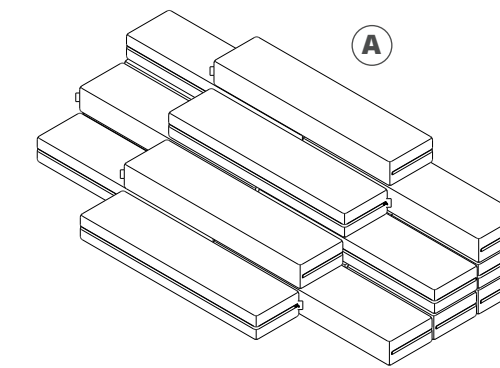

A. Genga™ Maxi Collection 10-C0225 **B.** Amphi™ Jnr.02 10-C0190 **C.** BagGrab™ Hook 14-W0001 **D.** PebbleTree™ Low Collection with WorkPad™ Caddy 10-C0840

Lower Elementary Classroom

Here's to the question askers, the naptime avoiders, the brilliant storytellers, and the limitless imaginers.

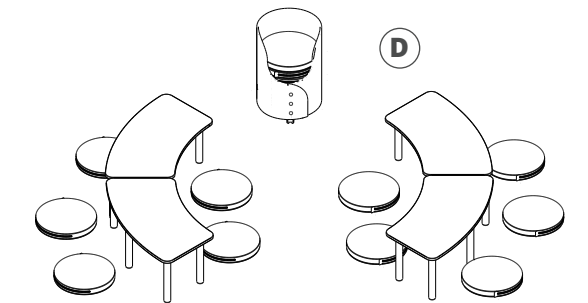
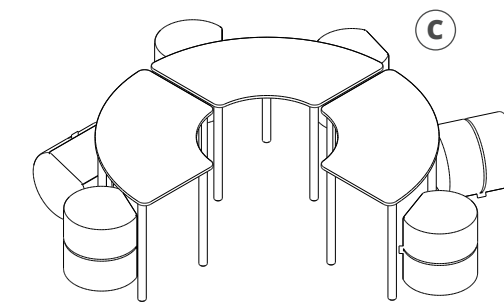
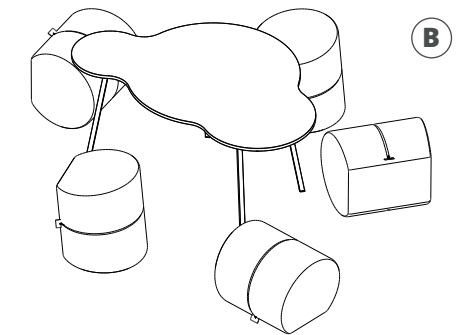
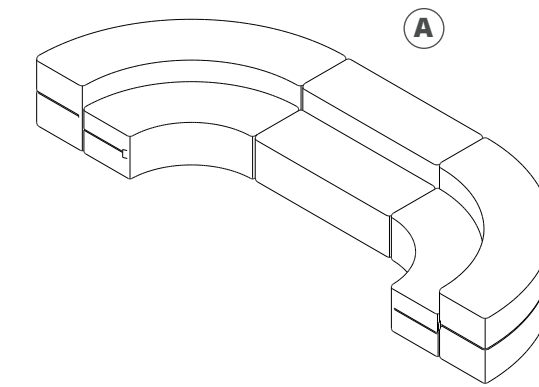

A. Amphi™ Jnr.03 10-C0245 **B.** SunshineOnACloudieDay™ Jnr Collection 10-C0010 **C.** Intensive Teaching Station™ 10-C0105
D. Perch Low Collection 10-C0635

Upper Elementary Classroom

Here's to the test prep masters, the constant reconfigurators, the lesson plan dazzlers.

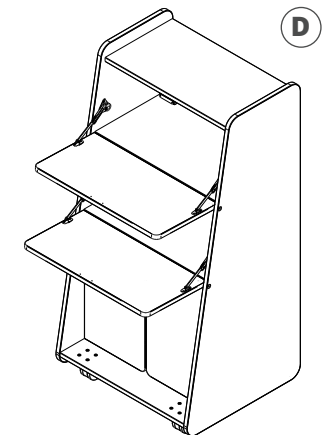
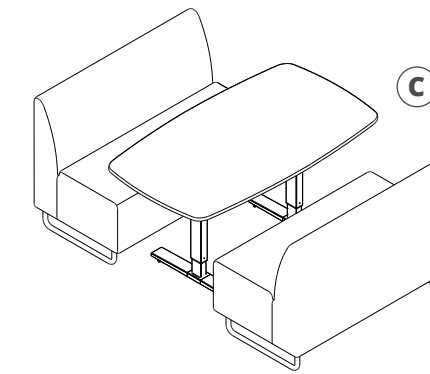
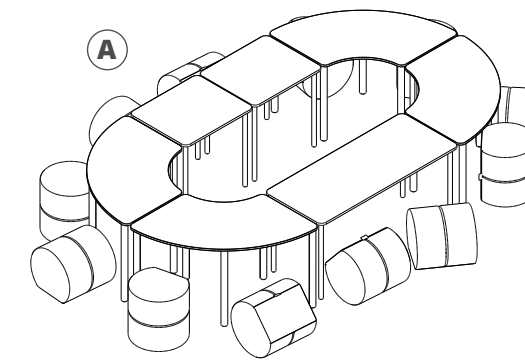

A. Collaborative.02 **10-C0051** **B.** SunshineOnACloudieDay™ High with STEAMspace™ Stools **10-C0600** **C.** Scofa™.01 **10-C0120**
D. EduStation **13-DG109**

Middle School Classroom

Here's to the pickle in the middle, the ups and downs roller coaster managers, the crafty engagers, the level-headed listeners, and the patience practicers.

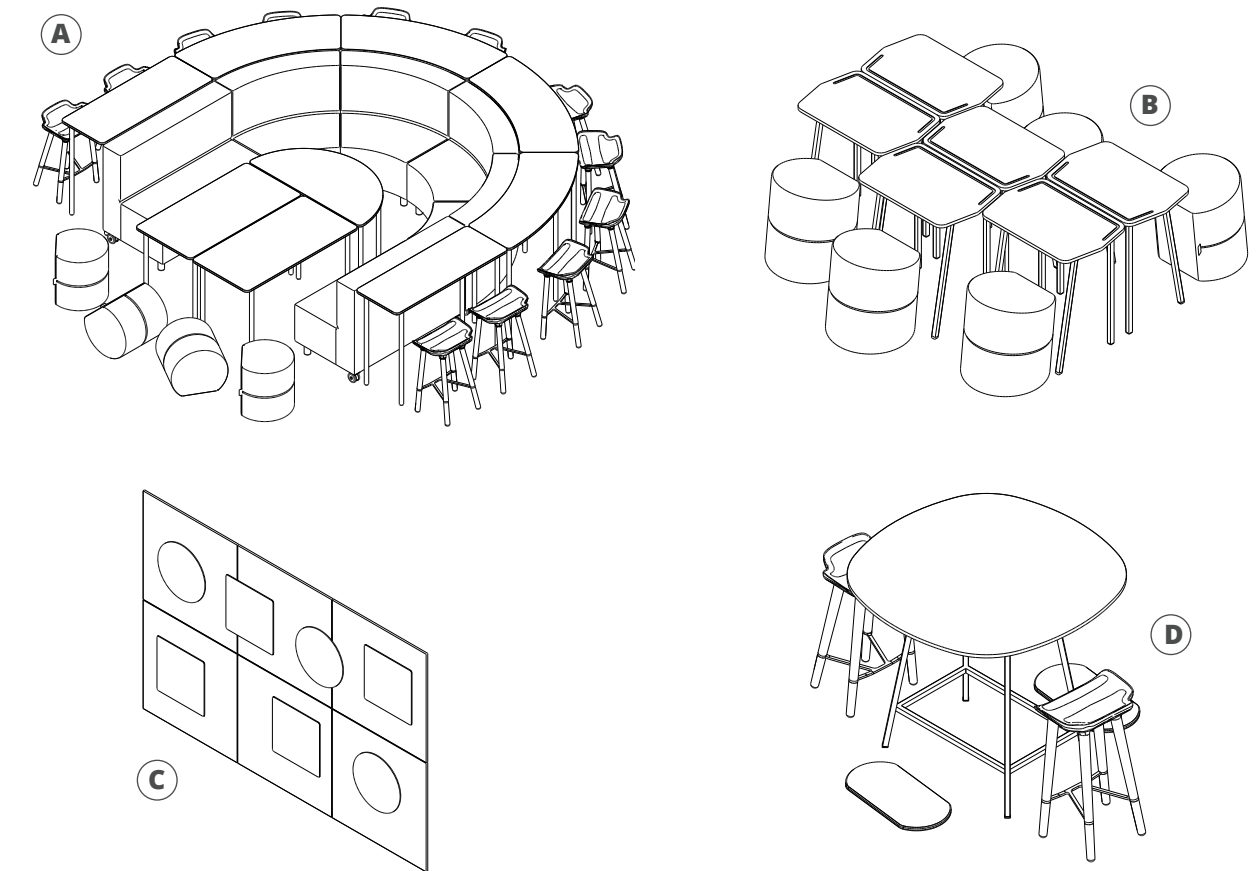

A. Conclave™ NNCG12 **10-C0165** **B.** Fabio™.01 **10-C0785** **C.** Acoustic Square Wall with Whiteboards **10-C0565** **D.** PebbleTree™ High Collection with STEAMspace™ Stools and NorvaBoards™ **10-C0581**

High School Classroom

Here's to the class advisors, the yearbook editors, the subject matter experts, and the last stop before the next steppers.

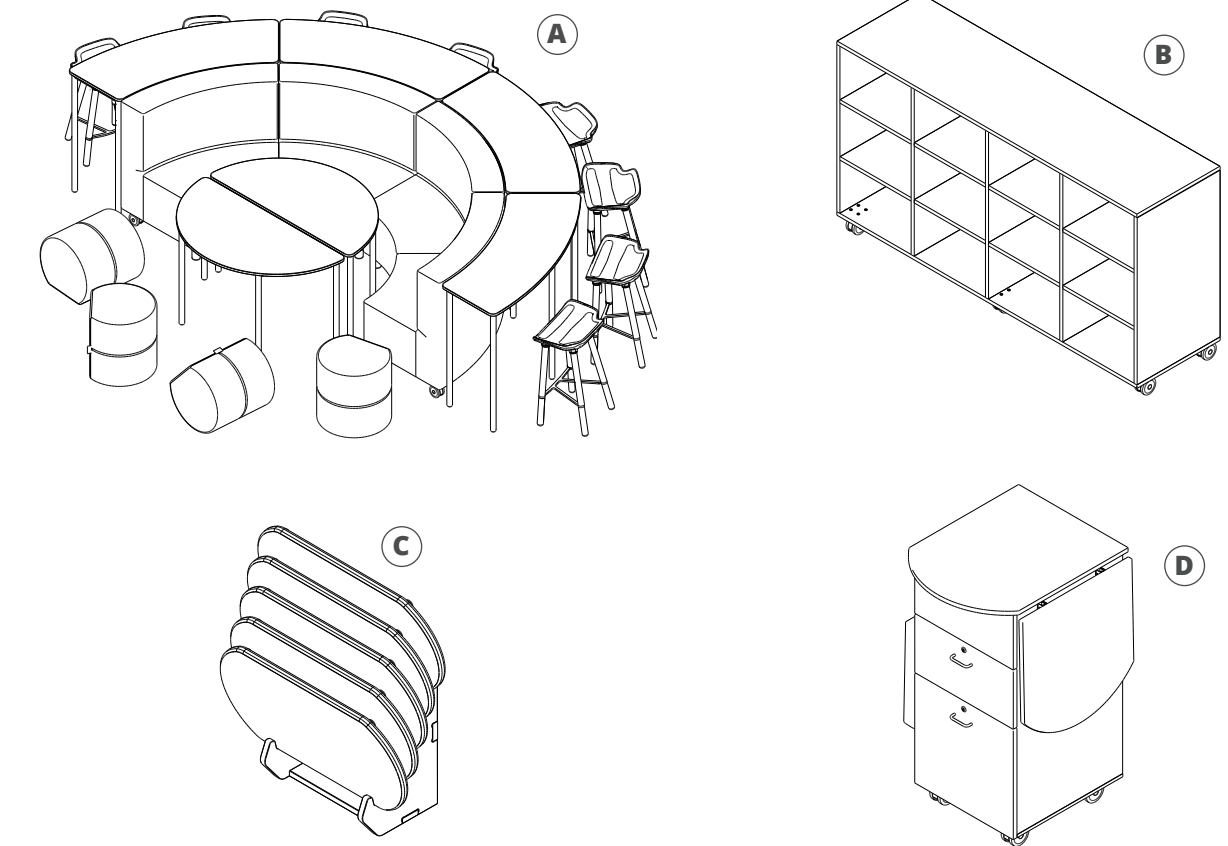

A. Conclave™ NNCG04 **10-C0940** **B.** Store And Draw™ 12 without Doors **13-DG011** **C.** NorvaBoard™ Collection with Stand **10-C0585** **D.** Teacher's Scaddie™ **13-DG020**

Learning is
a treasure
that will follow
its owner
anywhere.

— CHINESE PROVERB

Extended Learning Areas

The consideration of the in between spaces provides unique opportunities for extending and cultivating new learning practices, contributing to a visible culture of learning.

Your buildings, both old and new, present limitless spaces to connect in places unused or previously unimagined. These informal learning spaces align flexibly to individual learning styles, while fostering positive socialization skills in often underutilized spaces.

Designed to facilitate variability, these spaces only amplify our opportunities for learning, heighten our experiences and connections, and create a strong sense of community and culture.

JUNIOR Community Commons

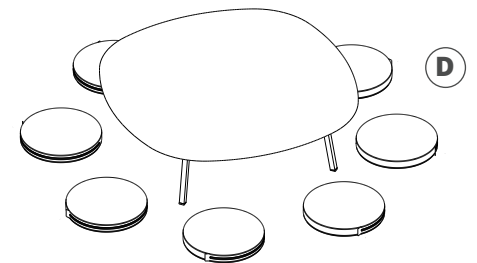
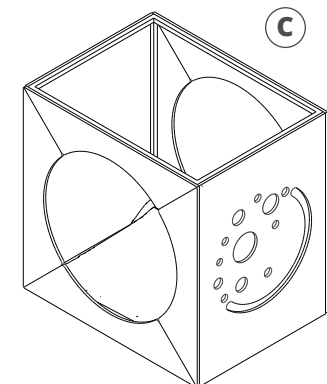
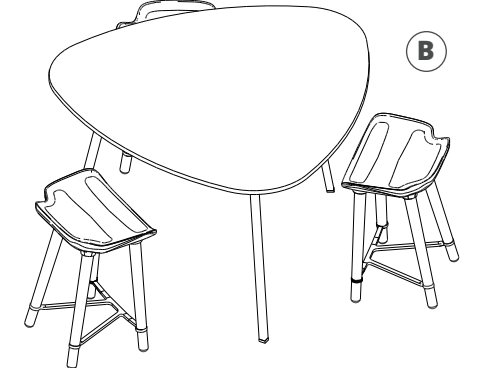
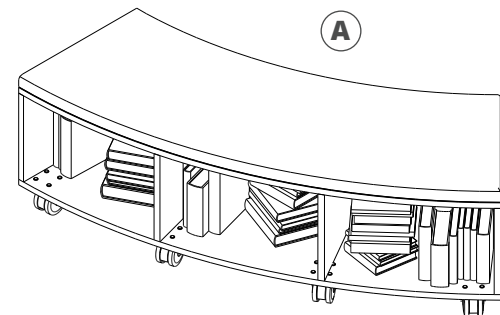

A. Conclave™ Upholstered Storage Bench Outer 10-C0945 **B.** STEAMspace™.06 10-C0485 **C.** IncuPod™ Nook 10-C0330
D. PebbleTree™ Low Collection with WorkPads™ 10-C0605

JUNIOR Collaboration Hallway

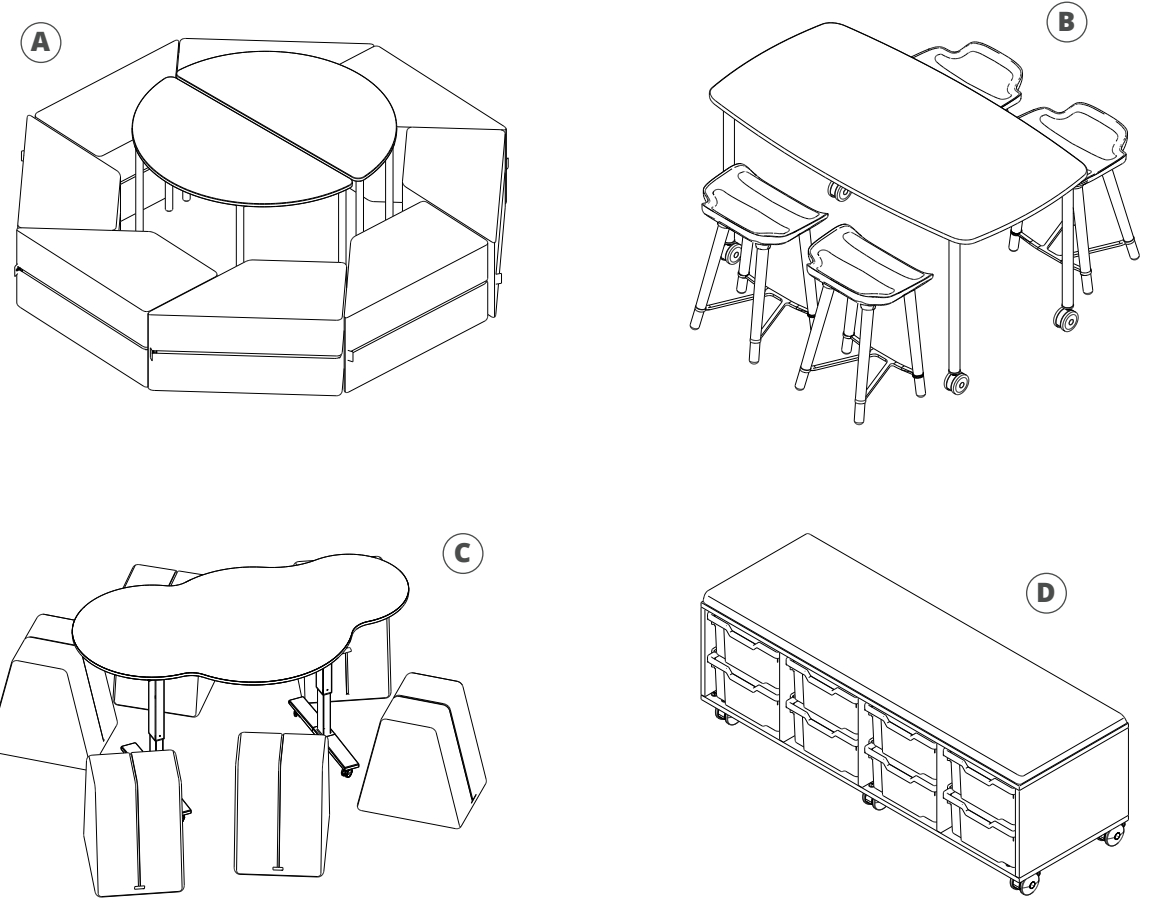

A. Amphi™ Bench.01 **10-C0835** **B.** STEAMspace™.03 **10-C0490** **C.** SunshineOnACloudieDay™ Foldable Collection **10-C0005**
D. Store And Draw™ Upholstered Caddy (8 Tub) **10-CA640**

SENIOR Collaboration Corridor

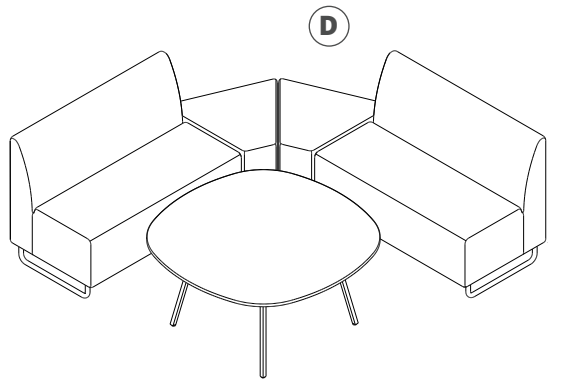
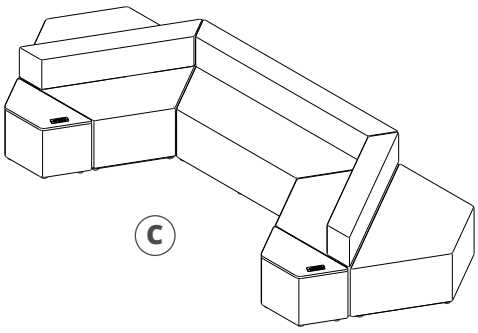
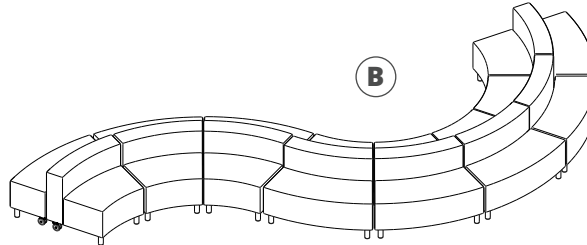
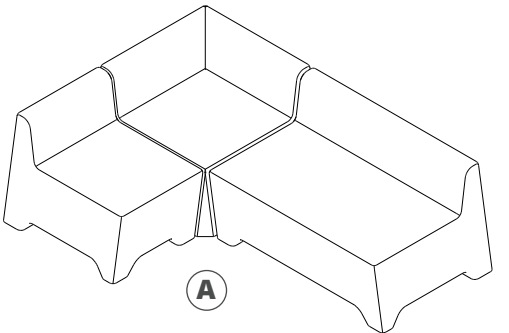

A. NorvaNivel Senior™ Collection **10-C0295** **B.** Conclave™ Hub Mini Collection **10-C0270** **C.** GizGaz™.03 **10-C0215** **D.** Scofa™.04 **10-C0300**

SENIOR Collaboration Commons

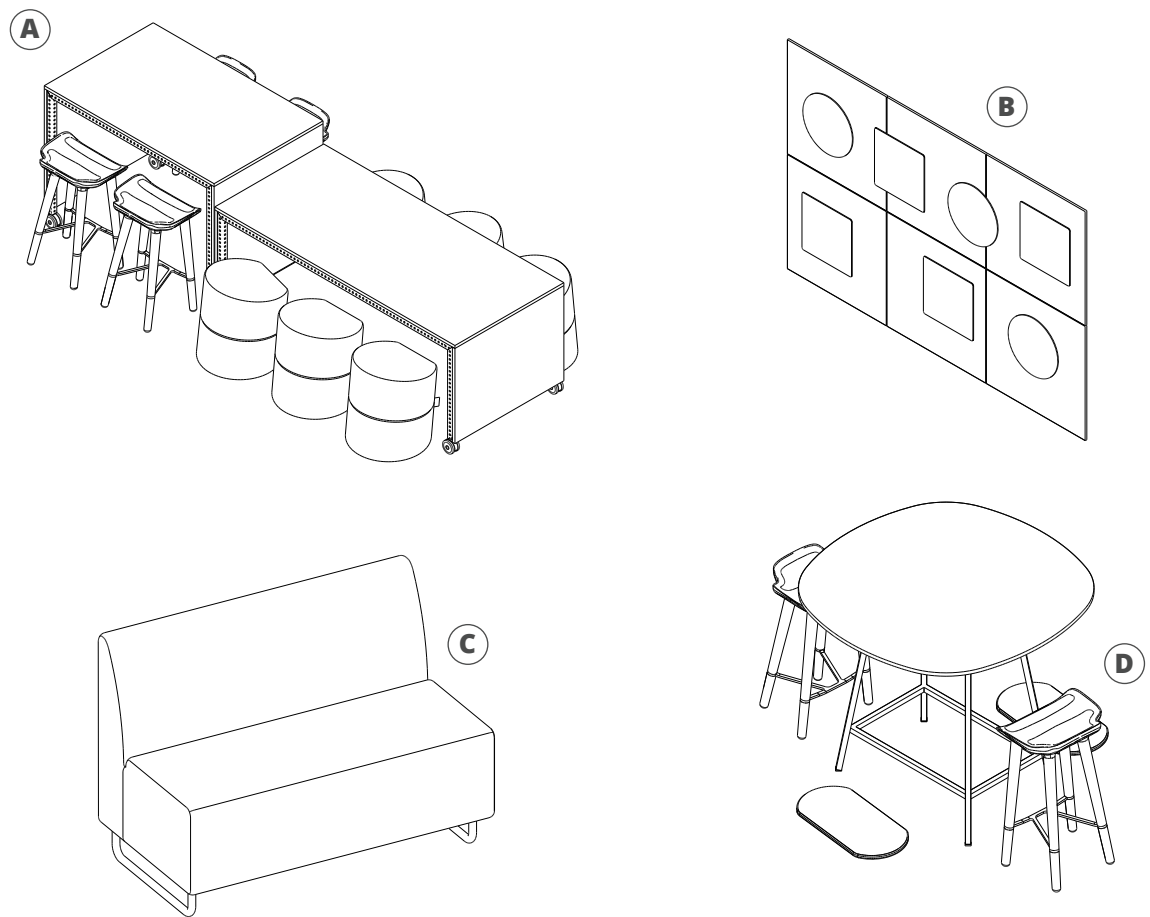

A. Slabwrx™.04 **10-C0670** **B.** Acoustic Square Wall with Whiteboards **10-C0565** **C.** Scofa™ Double without Arms **12-EJ010**
D. PebbleTree™ High Collection with STEAMspace™ Stools & NorvaBoards™ **10-C0581**

The best way
to predict
your future
is to create it.

— ABRAHAM LINCOLN

Make and Create

Making overlaps with our natural inclination to learn, by paving the way for more hands-on, discovery-based learning in today's schools.

A maker mindset encourages students to shift from passive users to active creators. It places value on the individual's ability to be the creator of things by promoting problem-solving, collaboration and critical thinking, while inspiring creativity and encouraging meaningful cross-curricular collaboration.

Maker and STEAM spaces encourage knowledge as a result of experience, deepening our connection to learning, and heightening our ability to discover unique passions and talents.

STEAMspace™

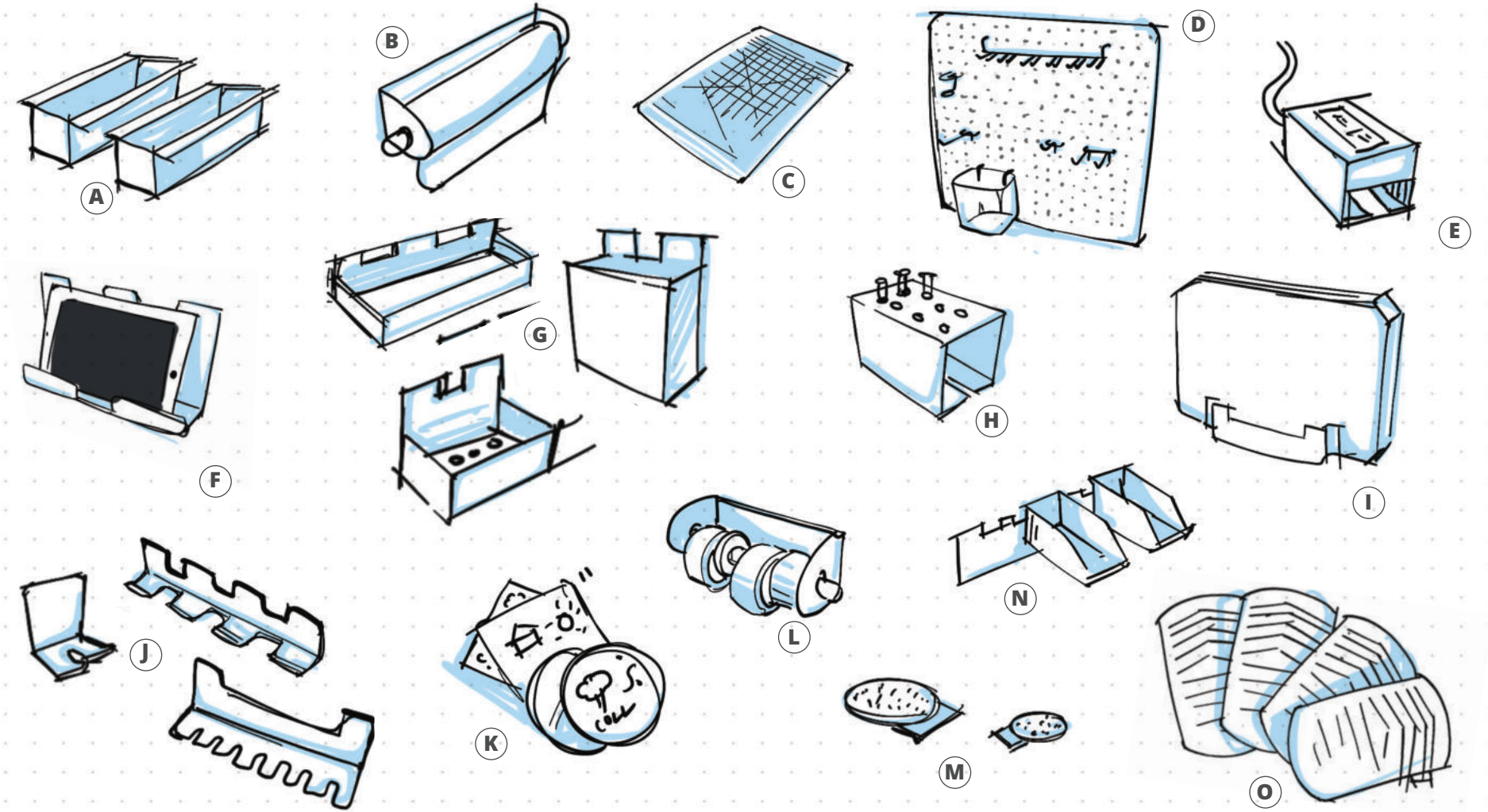
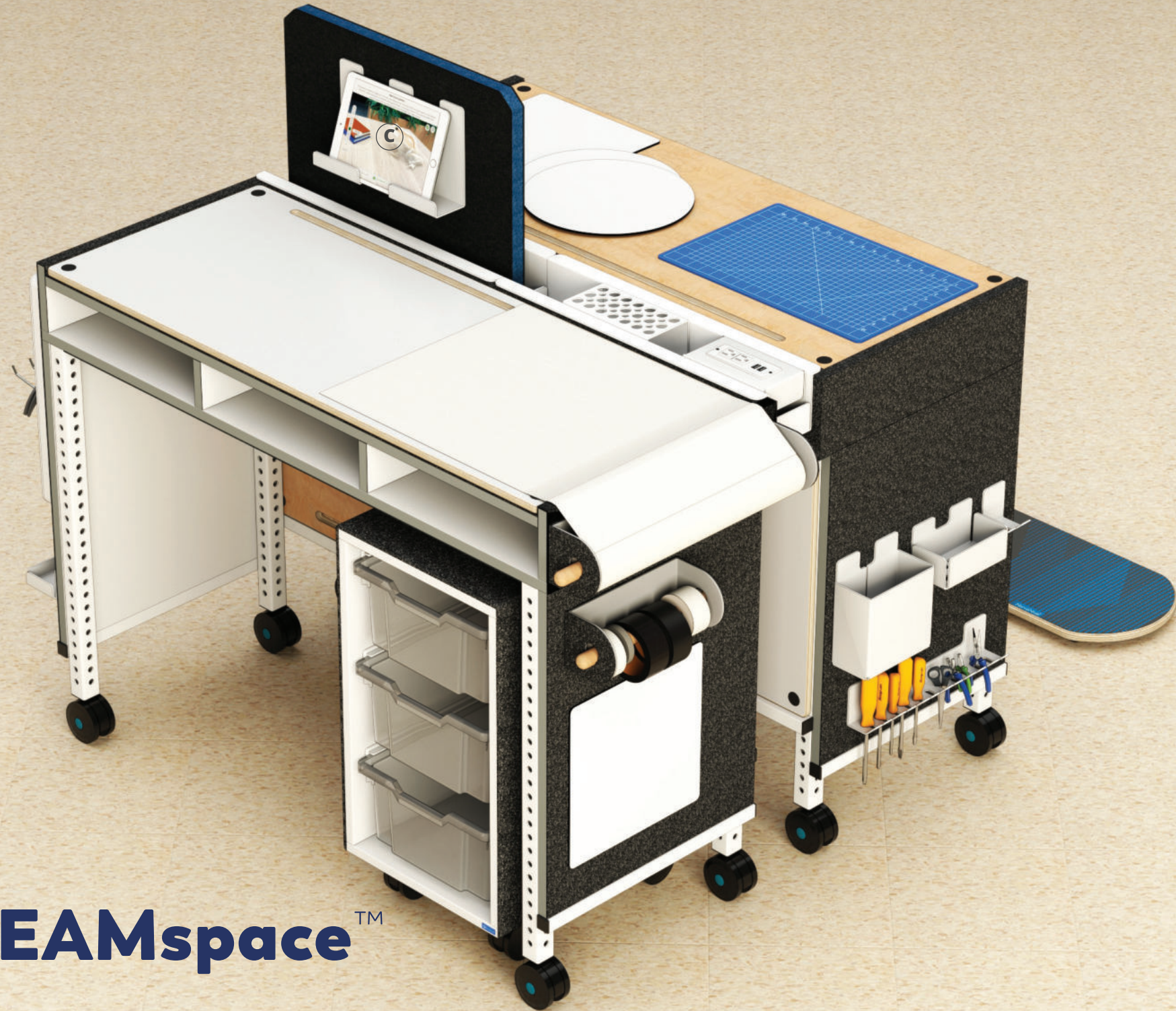

A. STEAMspace™ U Channel Holder | B. STEAMspace™ Paper Roll and Holder | C. STEAMspace™ Cutting Mat | D. STEAMspace™ Pegboard, 3 in Straight Hook, 5 in Double Hook, Multi-prong Hook, Double Ring Tool Holder, Peg Hook Plastic Bin | E. STEAMspace™ Power Module | F. STEAMspace™ Tablet Holder | G. STEAMspace™ Container Board Ledge, STEAMspace™ Container Tall Bin, STEAMspace™ Small Basket | H. STEAMspace™ Test Tube Holder | I. STEAMspace™ Dividing Screen, STEAMspace™ Screen Holder | J. STEAMspace™ Multi Hook, STEAMspace™ Single Hook, STEAMspace™ Hefty Hook | K. NorvaNivel Whiteboard Collection | L. STEAMspace™ Tape Holder | M. STEAMspace™ Hook and Loop Small Dot, STEAMspace™ Hook and Loop Large Dot | N. STEAMspace™ Tub and Shelf | O. NorvaBoard™

JUNIOR STEAM Space

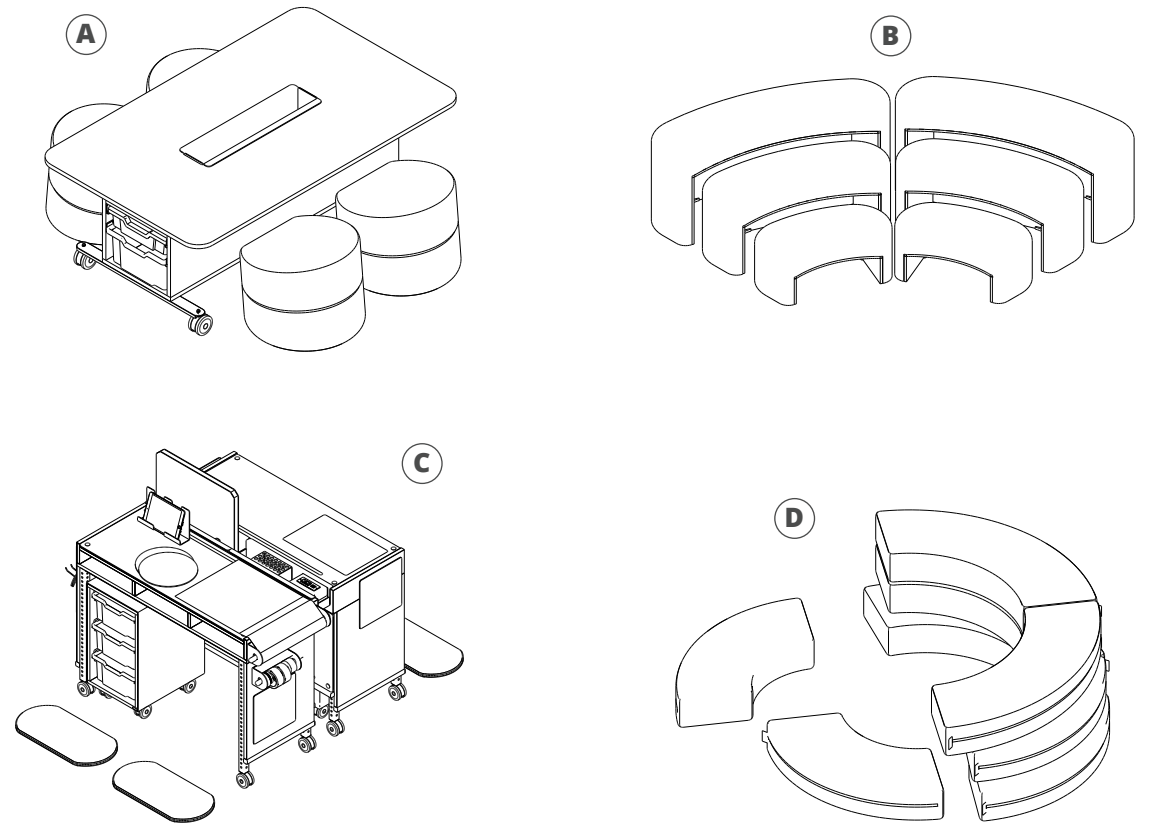

A. TeMakr™.01 10-C0825 B. Genci™.01 10-C0695 C. STEAMspace™.01 Jnr 10-C0375 D. Genga™ Curve Collection 10-C0610



SENIOR STEAM Space

A. Conclave™ NNCG12 10-C0165 B. STEAMspace™ 2 Wheel Table 10-T0075 C. STEAMspace™ 01 Snr 10-C0375 D. STEAMspace™ Snr Caddy (10 Tubs) 10-CA415

Our courage to try has allowed us to continue to innovate and push education forward.

— AVRON LEVIN

Cafe Commons

Our cafe spaces are at the center of creating a sense of community, culture, and social connection across ages and backgrounds.

These spaces feed our senses and our emotions; they bind us together and give us an understanding of our place in the world and our relationship to other people within it.

Our cafes are places where equity and socialization are at the core of the design: a safe space that fills our tummies and fuels our minds.

Today's cafeteria is being completely reimagined. A now vibrant and inclusive space, with abundant choice and opportunity to socialize and learn as a community, the cafeteria of the future is once again at the core of connection.

Cafeteria Space

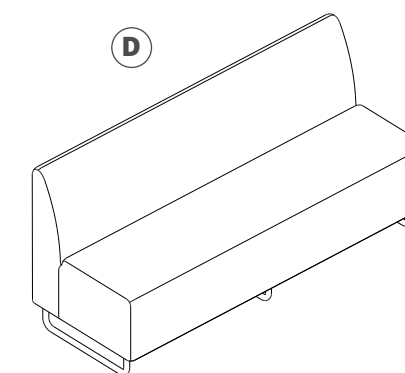
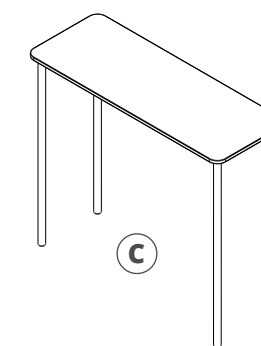
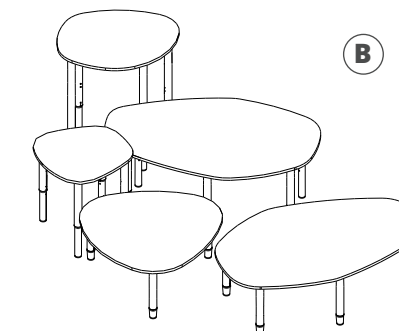
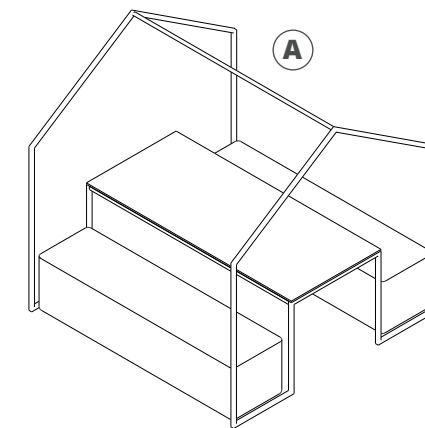

A. Collobana™ Snr Collection with Benches **10-C0115** **B.** Irregular Shape Tables **10-C0982** **C.** Perch Straight **10-T0175** **D.** Scofa™ Triple without Arms **12-EJ011**

**The more that
you read, the more
things you will
know. The more
you learn, the more
places you'll go.**

— DR. SEUSS

Media & Resource Center

Since its inception, the library has been a vital part of education. This space is the heart of knowledge and an evolving space for innovation, transforming the lives of communities by facilitating the creation of new knowledge.

A place designed to foster inquiry, collaboration, exploration and engagement, the library/media resource center of today seeks to develop curiosities and understanding by facilitating shared and equitable access to an enriching and diverse collection of resources.

The library is the hub of active learning, supporting constant evolution and maintaining the culture of knowledge immersion through experiential discovery.



JUNIOR Library

A. Conclave™ BC03 10-C0515 B. Irregular Shape Tables 10-C0982 C. Collobana™ Jnr Collection with RockerOtt.10™ 10-C0110 D. Learning Tree 08-JL007



SENIOR Media Resource Center

A

B

C

D

A. PebbleTree™ High Collection with NorvaBoards™ 10-C0595 B. Conclave™ NNCG09 10-C0845 C. Collaborative Foldable Table 10-T0275 D. Conclave™ BC13 10-C0935

Being in your
element is not
only about aptitude,
it's about passion:
it is about loving
what you do.

— SIR KEN ROBINSON

Faculty Collaboration

The role of the educator is in continuous motion, evolving rapidly and fluidly, adapting with the changing and varied needs of each learner and the constant innovation in both what and how we teach.

Architects of learning, change agents in the process of our progression, and role models for both learners and peers, today's educators are vital to the school ecosystem.

These incredible doers, leaders, instructors, and mentors deserve spaces designed to encourage the sharing of ideas, stories, and successes. Spaces that speak to the culture of the school's vision, offer support, reprieve and restoration, while reflecting the same ingenuity in agility and adaptability as the facilitators of knowledge working within them.

FACULTY Staff Room

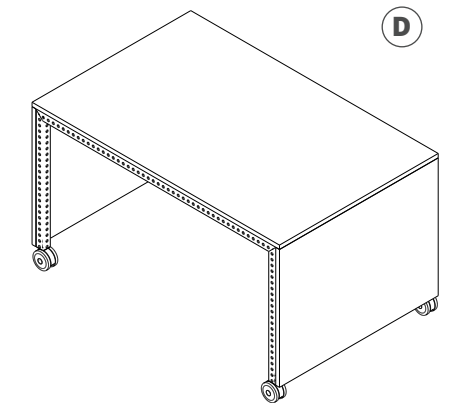
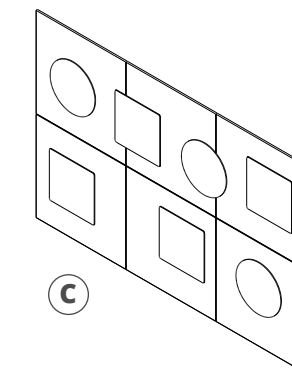
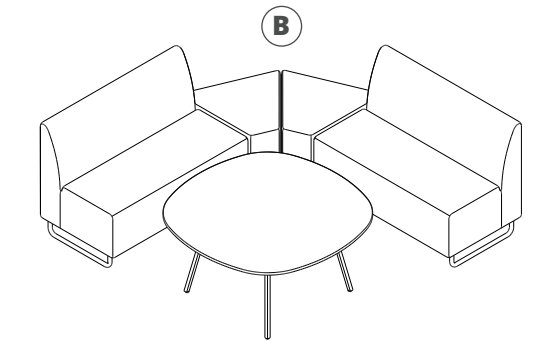
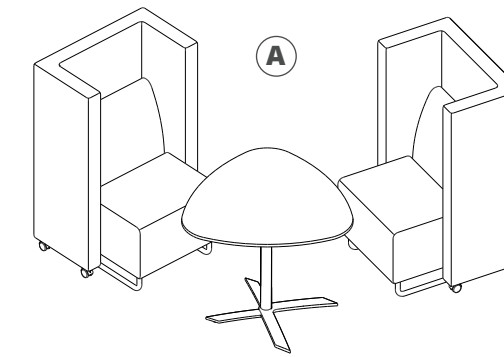

A. Scofa™.03 **10-C0126** **B.** Scofa™.04 **10-C0300** **C.** Acoustic Interactive Square Wall Collection with Whiteboards **10-C0565**
D. Slabwrx™ Short Table **10-T0200**

FACULTY Team Workspace

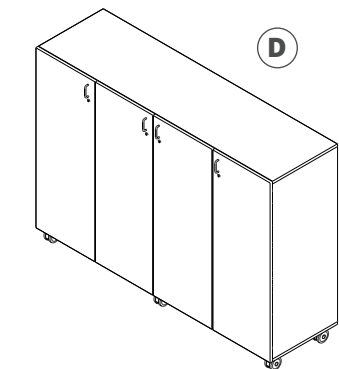
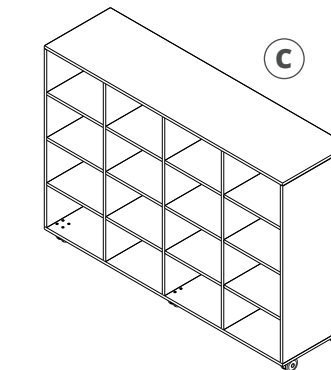
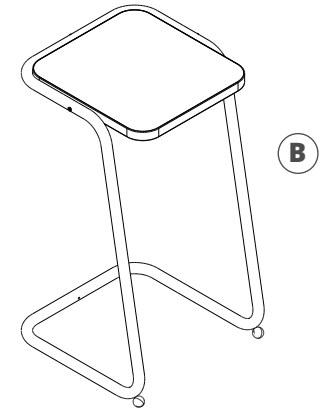
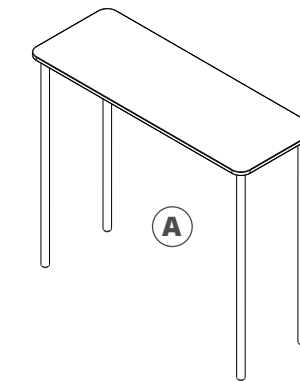

A. Perch Straight **10-T0175** **B.** Hugo Table **10-T0360** **C.** Store And Draw™ 16 without Doors **13-DG012-ND** **D.** Store And Draw™ 16 with Doors **13-DG012-D**

Teacher's Scaddie™

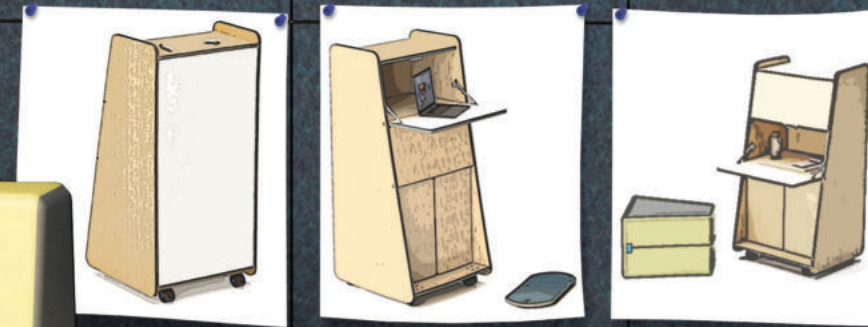
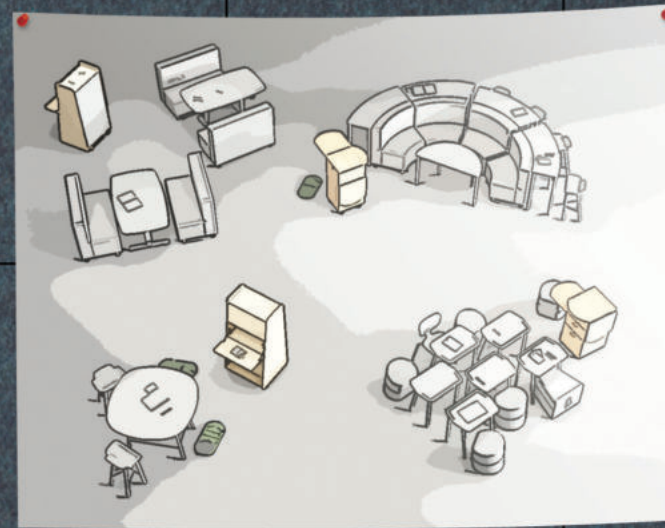
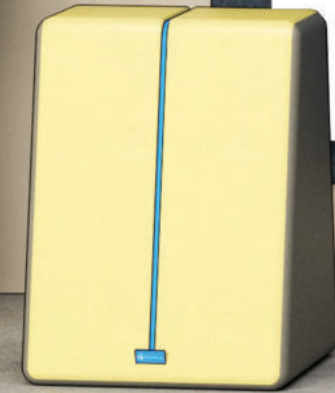
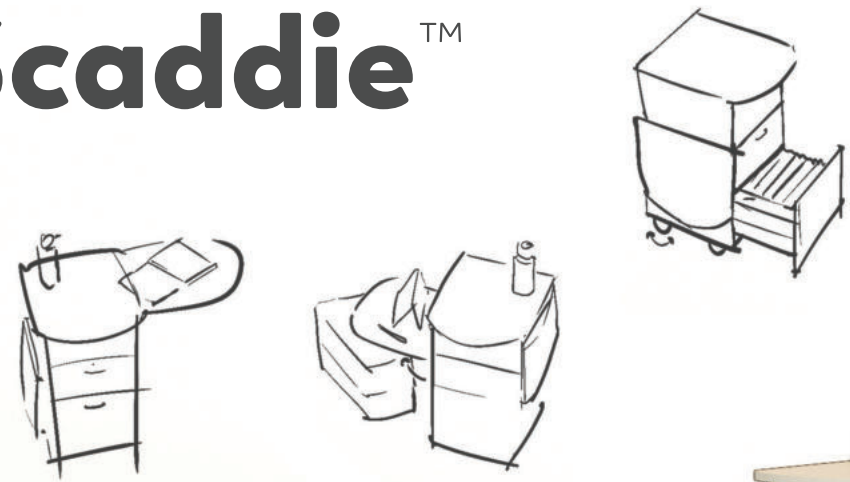

& EduStation

Great things
are done by a
series of small
things brought
together.

— VINCENT VAN GOGH

Specialty Spaces

Specialty spaces are those designed to meet specific needs of curriculum and learners.

These spaces are an extension and enrichment of the main learning environment and are designed to support a more customized approach facilitating more specialized activities.

Functional intent is key to creating harmonious spaces and collaboration is at the core of their design.

Music Space

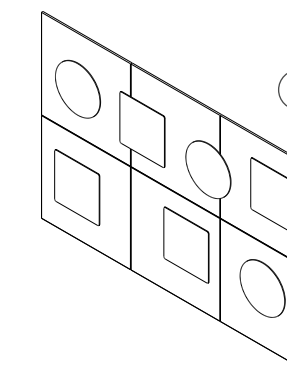
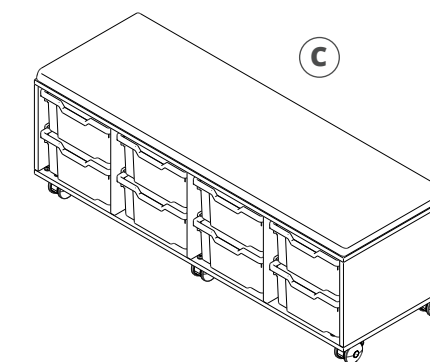
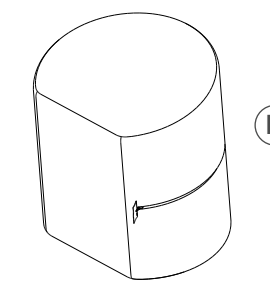
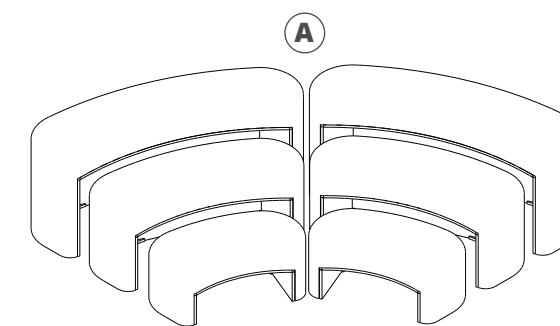

A. Genci™.01 **10-C0695** **B.** RockerOtt.10™ **11-SG068** **C.** Store And Draw™ Upholstered Caddy (8 Tub) **10-CA640** **D.** Acoustic Square Wall with Whiteboards **10-C0565**

Art Space

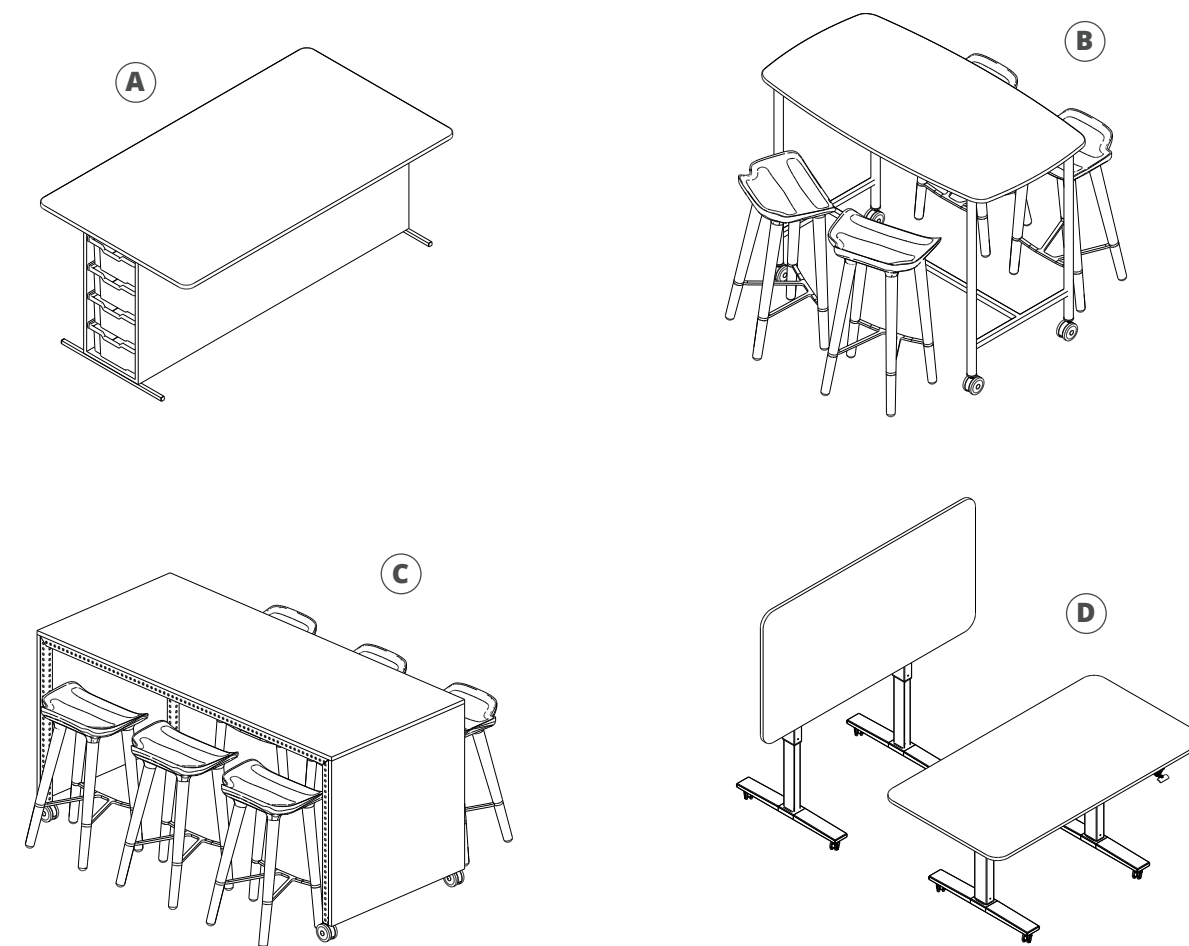

A. STEAMspace™ T-Table 6 Seater **10-T0225** **B.** STEAMspace™.02 **10-C0495** **C.** Slabwrx™.02 **10-C0660** **D.** Collaborative Foldable Table **10-T0275**

Resource Room

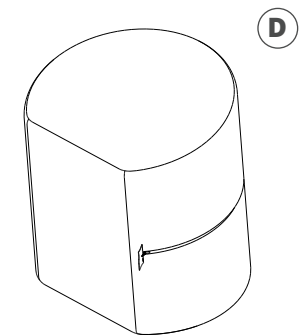
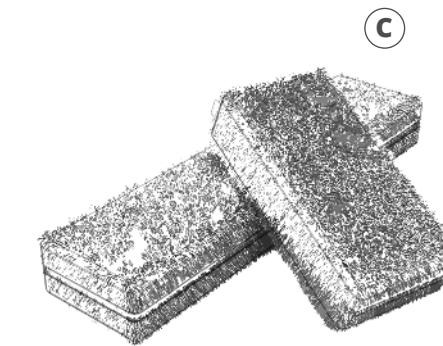
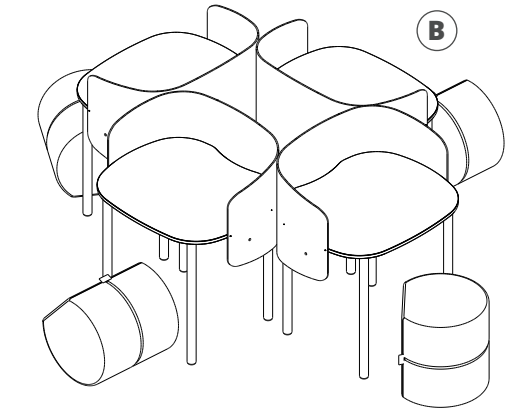
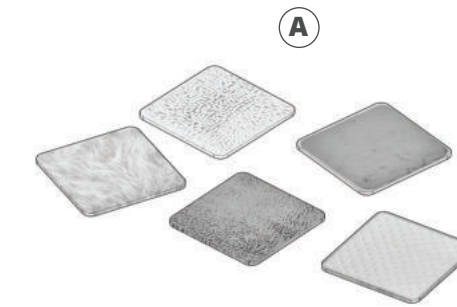

A. TacTiles™ 10-C0931 **B.** PebbleTree™ Study Collection 10-C0370 **C.** Genga™ Large Grassy 11-SG007-G **D.** RockerOtt.10™ 11-SG068

Esports

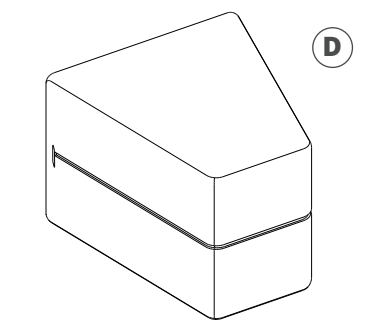
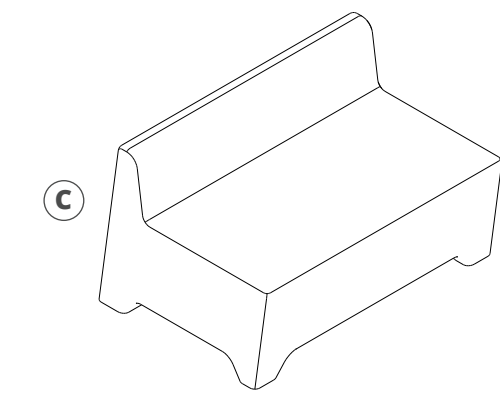
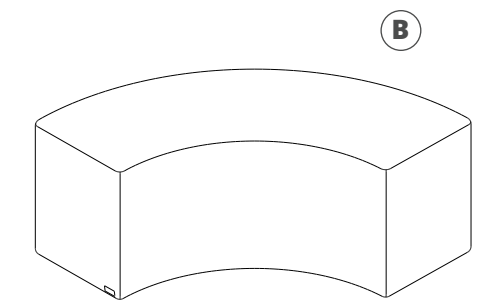
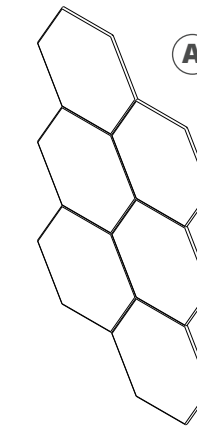

A. Acoustic Hex Wall without Whiteboards **10-C0810** **B.** Amphi™ Snr High Inner Tier **12-EJ020** **C.** NorvaNivel Senior™ Double **12-EJ015** **D.** SeedPod™ **11-SG010**

Atrium

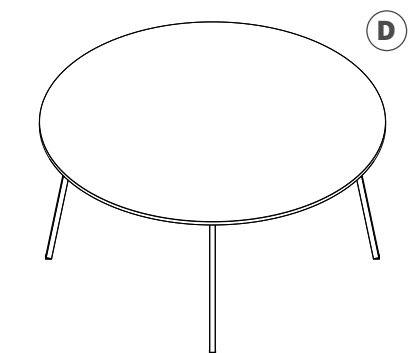
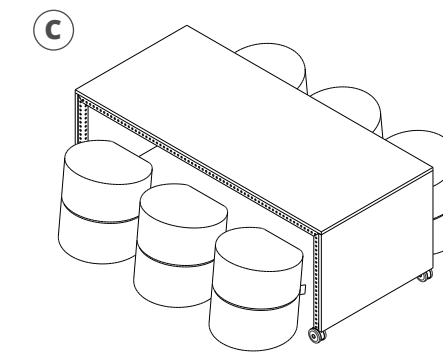
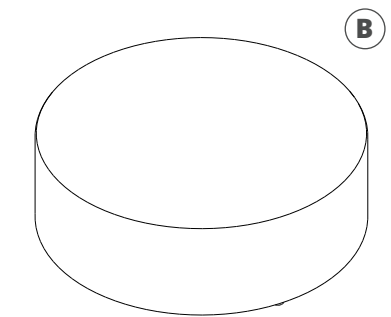
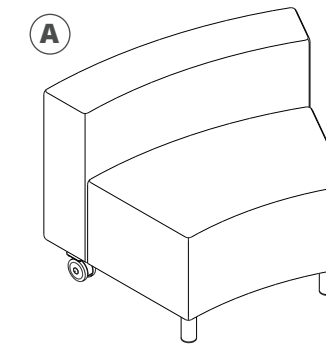

A. Conclave™ Hub Low Back 12-EJ005 **B.** Circle Round Large Ottoman 12-EJ062 **C.** SlabwrX™.01 10-C0655 **D.** Round Table 10-T0315

Education is the most powerful weapon you can use to change the world.

— NELSON MANDELA

Higher Ed

Preparing learners for life after school has never been a more daunting task.

Today's colleges and universities need to equip learners with the transversal skills needed to tackle the ever-evolving workplace. Skills such as collaboration, communication, creativity, critical thinking, community, connectivity and grit are in the highest demand.

Spaces in higher education facilities need to reflect our ever-changing world.

Dorm Commons

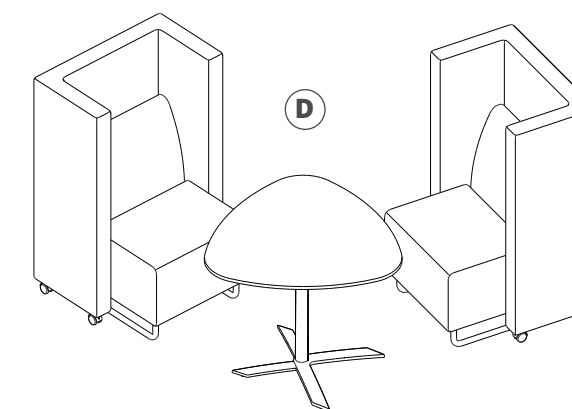
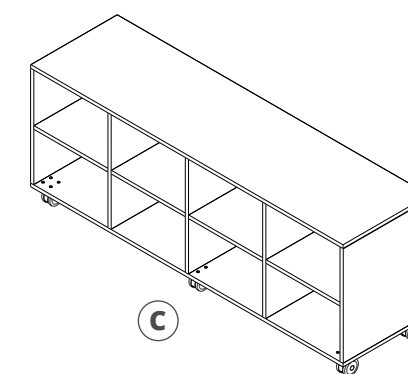
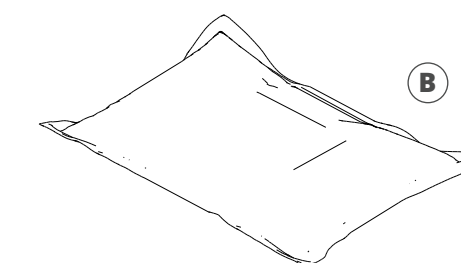
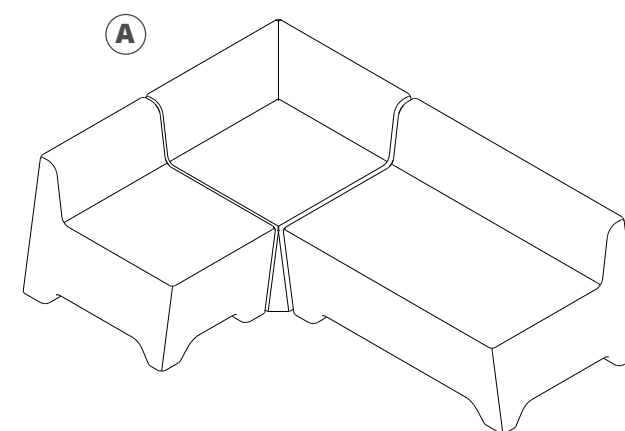

A. NorvaNivel Senior™ Collection **10-C0295** **B.** CrashPod™ **99-0001** **C.** Store And Draw™ **8 13-DG010** **D.** Scofa™.03 **10-C0126**

Student Union

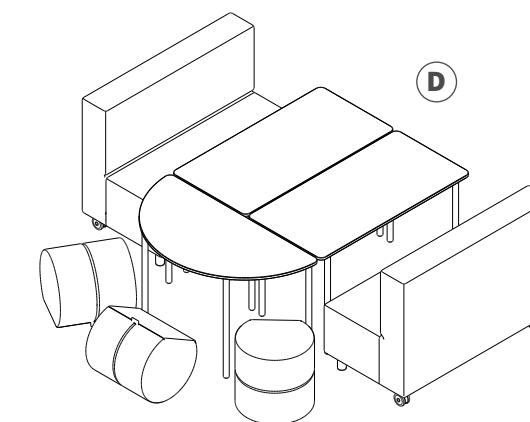
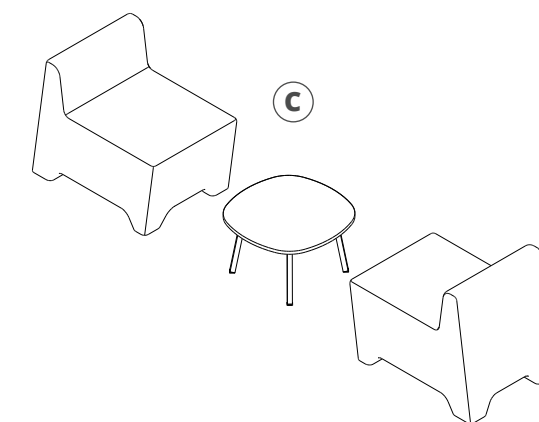
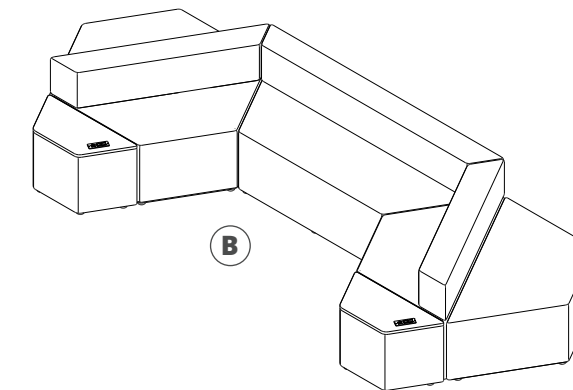
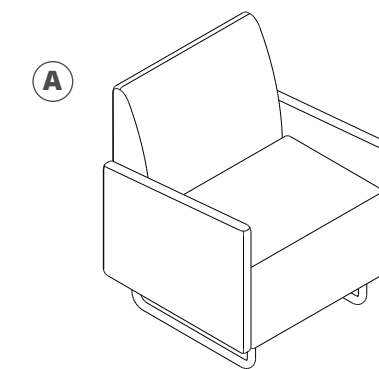

A. Scofa™ Single with Arms 12-EJ058 **B.** GizGaz™.02 10-C0205 **C.** NorvaNivel Senior™ Meeting Spot 10-C0305 **D.** Conclave™ NNCG09 10-C0845

We dream to write a new story in education...

A story not just about intellectual achievement and measurable knowledge, but one that is also about the heart, emotions, relationship, love, generosity, resilience, compassion and variability.

All of these values combined will create a new system in which we celebrate the individual and create a path where discovery of oneself and one's passions are presented as new and perpetual opportunities now and forever.



We will continue to create inspiring products

and spaces that refuse to do anything but take us to the place where we strive to be.

Silvertext

BY SPRADLING TEXTILES

VINYL

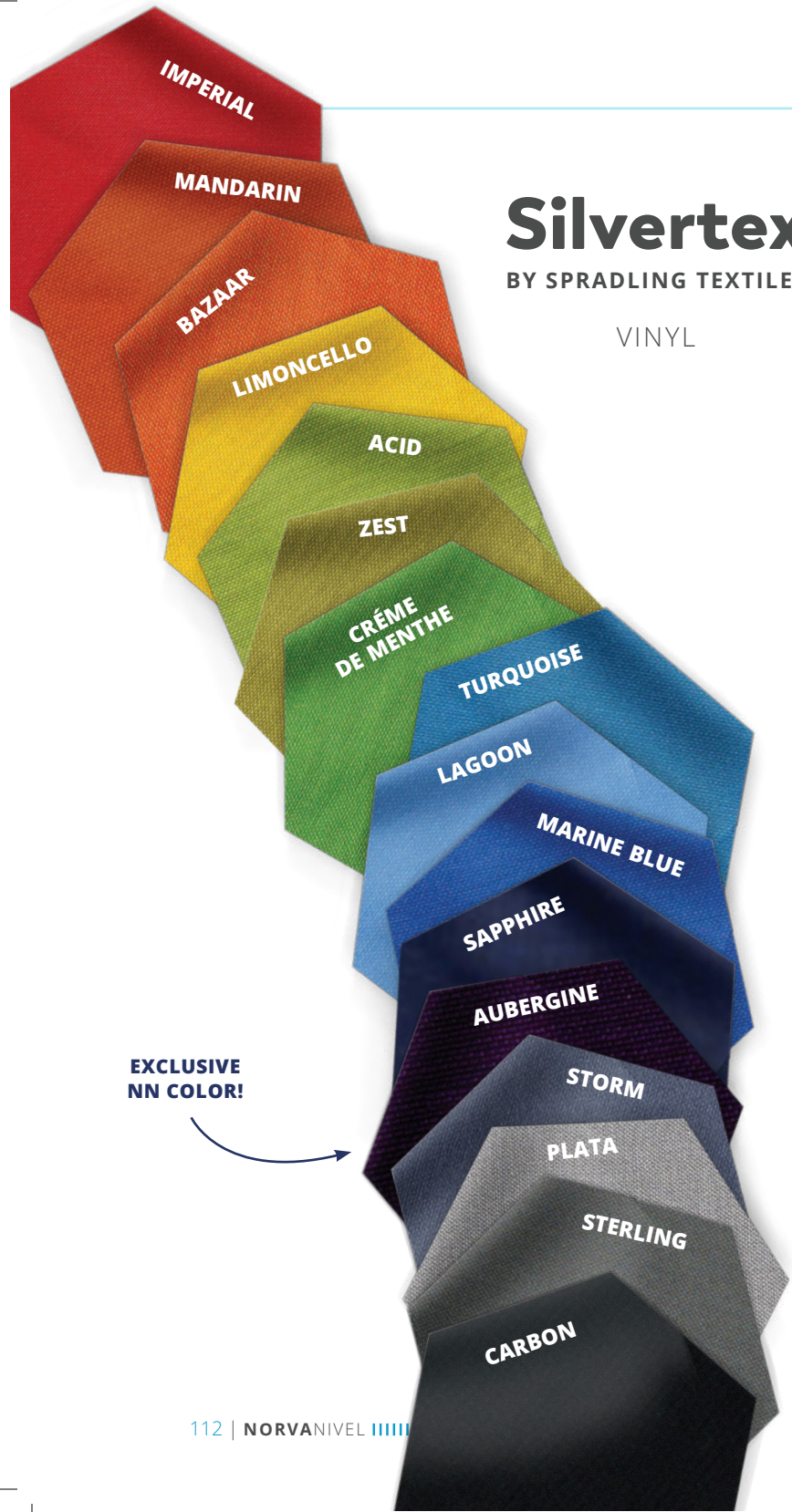

Maglia

BY SPRADLING TEXTILES

VINYL



Kilkinney

BY SPRADLING TEXTILES

NEW

VINYL



Guardian

BY SPRADLING TEXTILES

VINYL

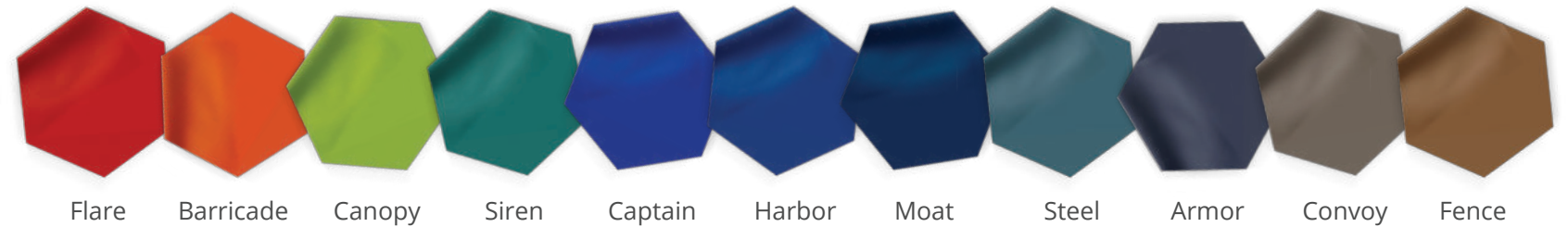

Modena

BY SPRADLING TEXTILES

NEW

VINYL

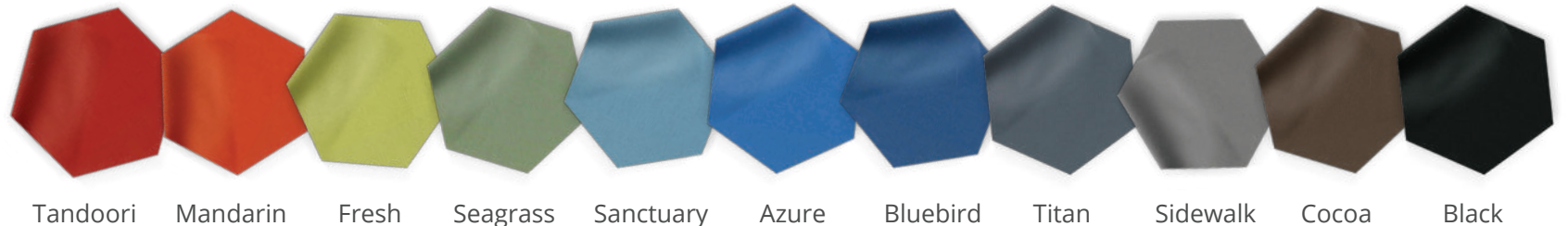

Edgeline BY SPRADLING TEXTILES

VINYL

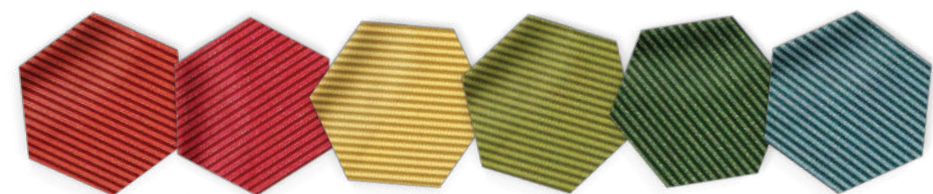

Autumn Ruby Mustard Olive Clover Atlantic

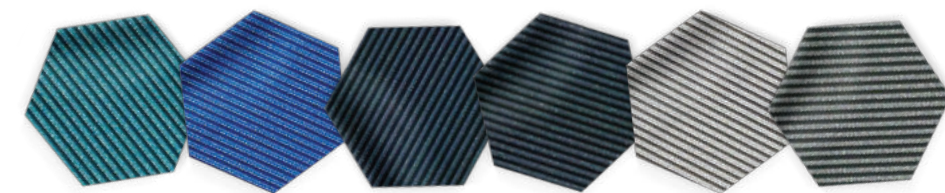

Peacock Royal Midnight Storm Pewter Graphite

GrabBag Baton Colors

THE HOOK IS ALWAYS WHITE.



White Blue Orange Green Natural Black

Vanguard CV

BY MOMENTUM TEXTILES

NEW

VINYL

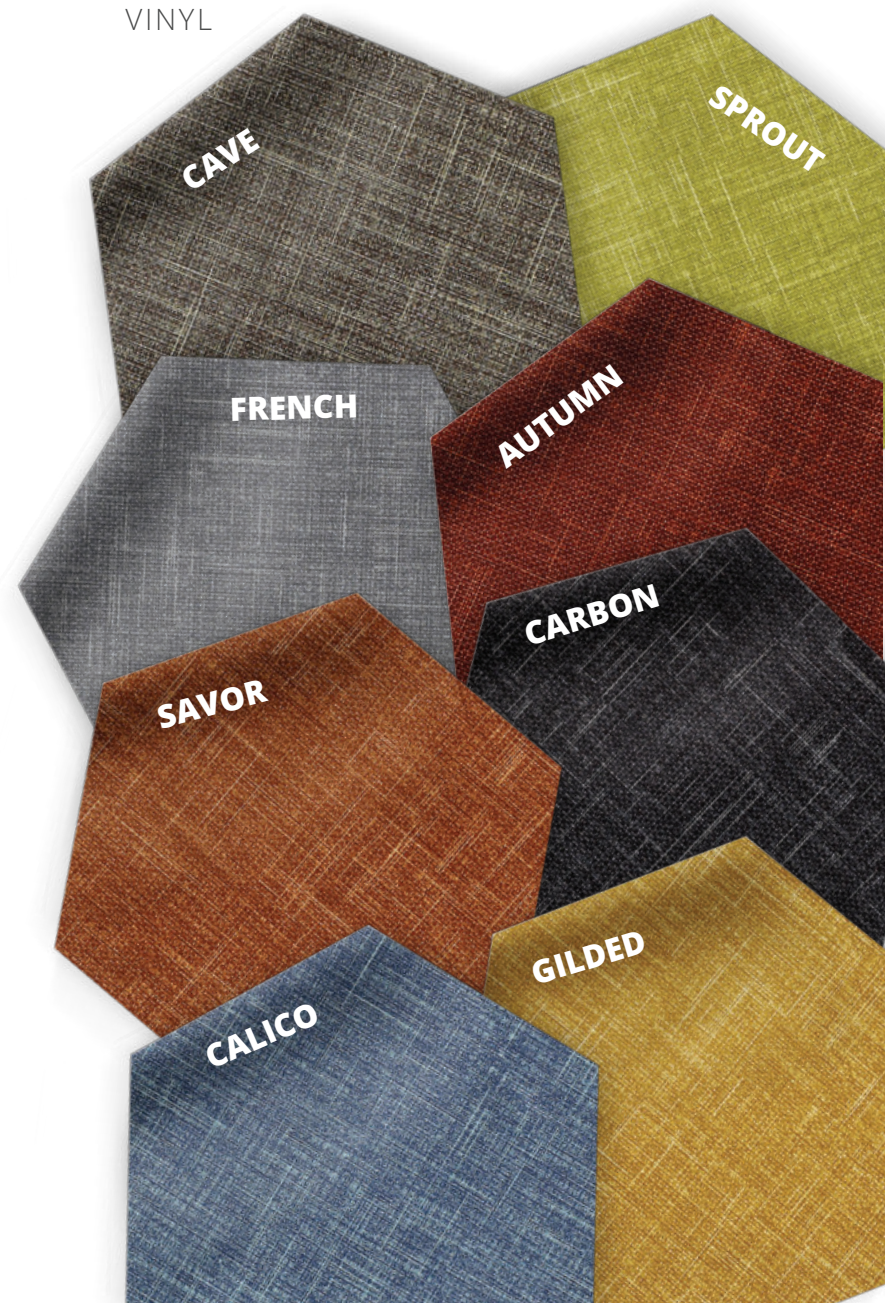

Evo CV BY MOMENTUM TEXTILES

NEW

VINYL



Tribeca CV

BY MOMENTUM TEXTILES

NEW

VINYL



Acoustic Tile

100% RECYCLED POLYESTER FIBER FELT

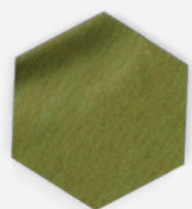

Lime

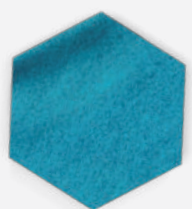

Aqua

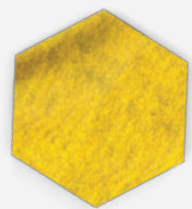

Lemon



Orange



Silver



Charcoal



Denim

STEAMspace™ Tub Colors

OTHER COLORS AVAILABLE UPON REQUEST



White



Silver



Cyan Blue



Royal Blue



Lime Jolly



Translucent

Surface Finishes



Astro Strandz



Black Riftwood



Brite White



Mouse



Natural Ash



Sand Maple

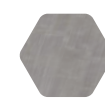

Silver Alchemy*



Writable White

Edgebanding Finishes



Astro Strandz



Black Riftwood



Brite White



Clementine



Mouse



Natural Ash



Sand Maple



Silver Alchemy*



Spectrum Blue



Vibrant Green

* Chemical Resistant or laminate

STEAMspace™ & Slabwrx™ Frame Finishes



Silver



STEAM Blue



White

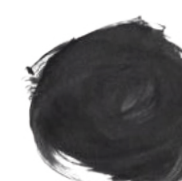

Black

Table Leg Finishes



White



Gray



Silver



Black

STEAM Carpet Backing



Charcoal Gray

Bookcase Backing Options



Matching Carcass



Writable White

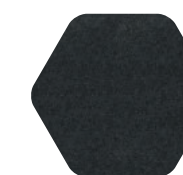

Charcoal Gray

NorvaBoard™

NORVA-GRIP POLYMER SURFACE

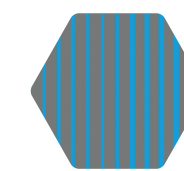

Blue/Gray

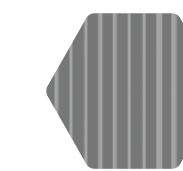

Gray/Gray

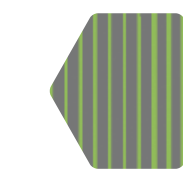

Green/Gray

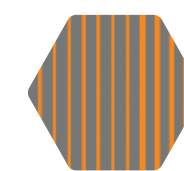

Orange/Gray



NorvaBoard™ 2021 Limited Edition

COLLECTIBLE ART NORVABOARD™!

Index

COLLECTIONS

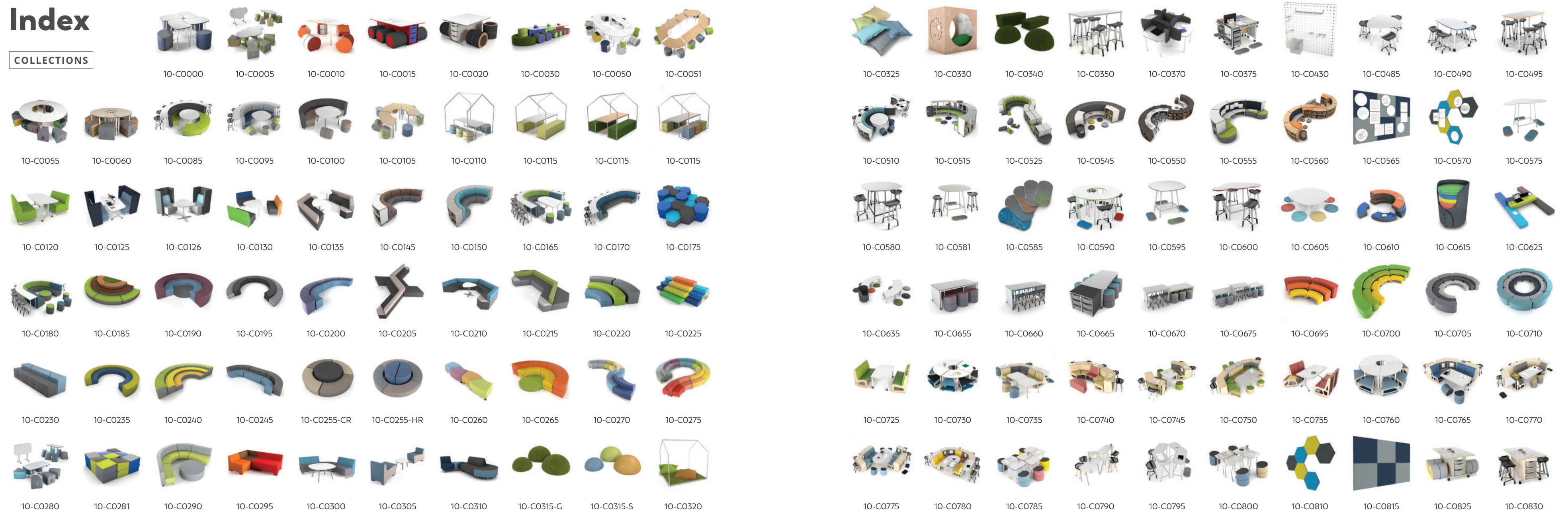

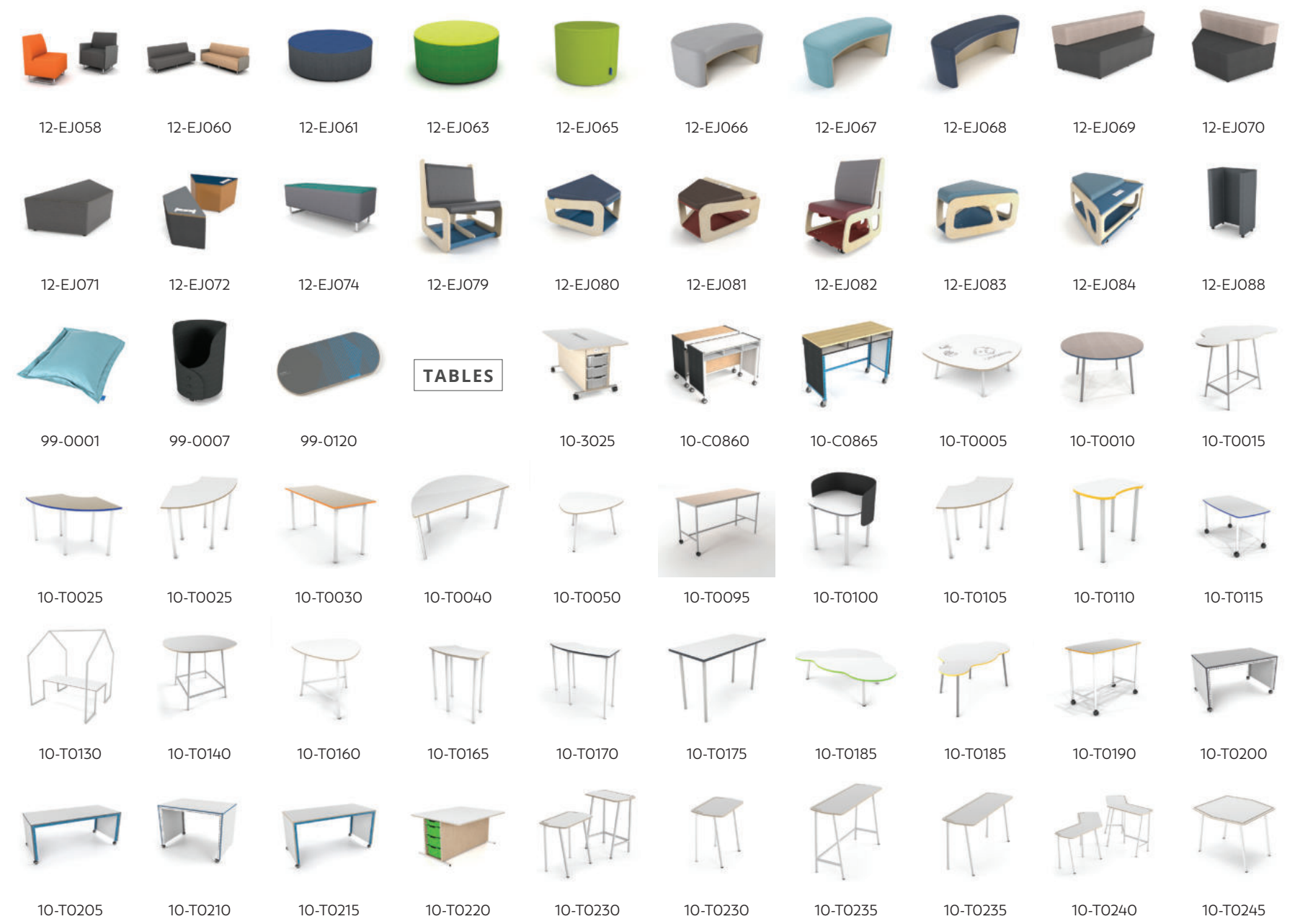
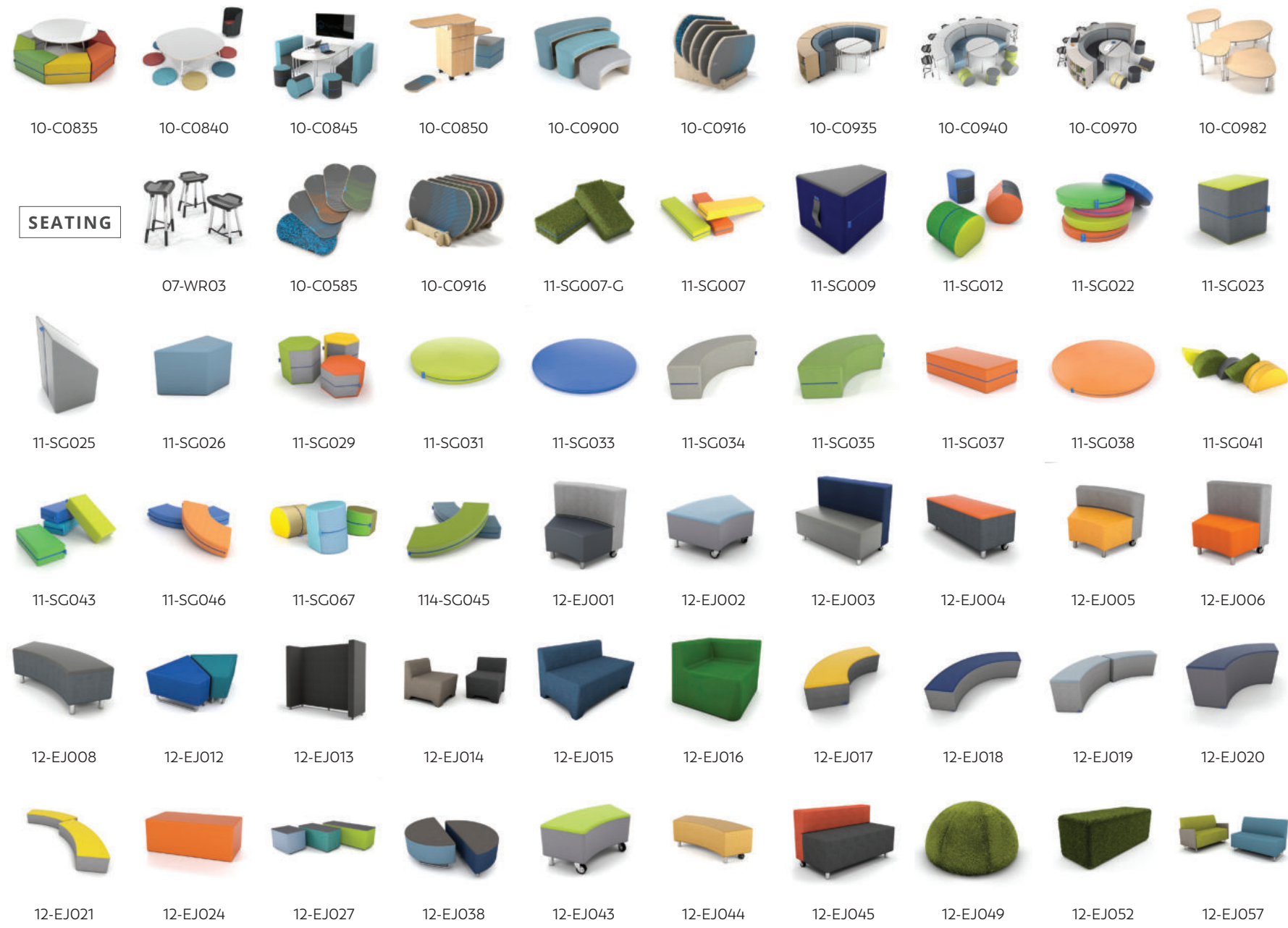

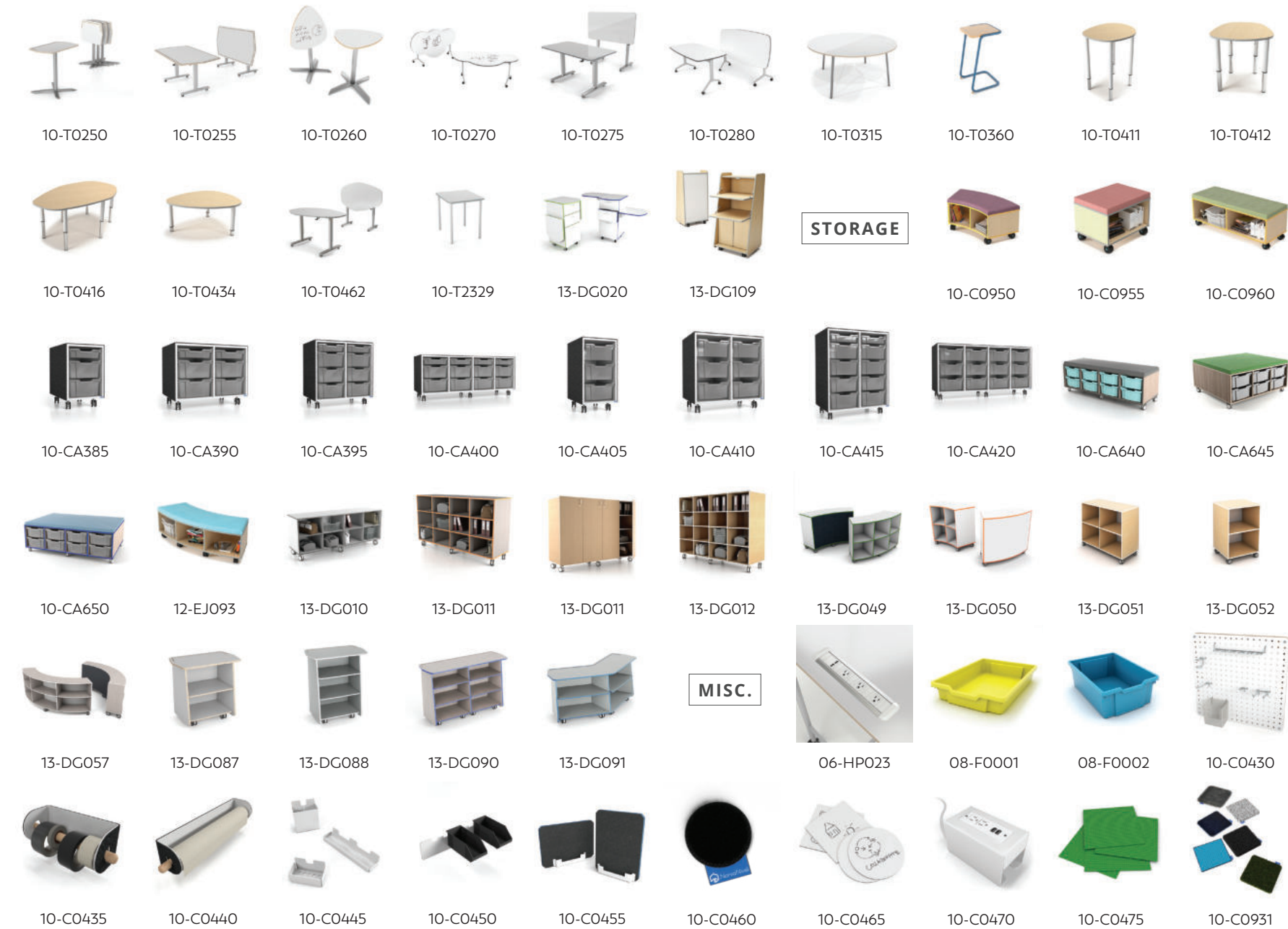

NORVANIVEL'S HELPFUL Height Guide

| SEATED HEIGHTS | | | | | STANDING HEIGHTS | | | | |
|--------------------|-----|-----|-----|-----|--------------------|-----|-----|-----|-----|
| Chair Height | 12" | 14" | 16" | 18" | Chair Height | 16" | 18" | 25" | 28" |
| Table Height | 22" | 24" | 27" | 28" | Table Height | 26" | 28" | 35" | 41" |
| Pre-K > 4 Year Old | | | | | Pre-K > 4 Year Old | | | | |
| Kindergarten | | | | | Kindergarten | | | | |
| Grade 1 | | | | | Grade 1 | | | | |
| Grade 2 | | | | | Grade 2 | | | | |
| Grade 3-4 | | | | | Grade 3-4 | | | | |
| Grade 5 | | | | | Grade 5 | | | | |
| Grade 6-12 | | | | | Grade 6-12 | | | | |

THIS CHART IS ONLY A GUIDE.
Our Education Specialists are available to consult with you on a case-by-case recommendation.



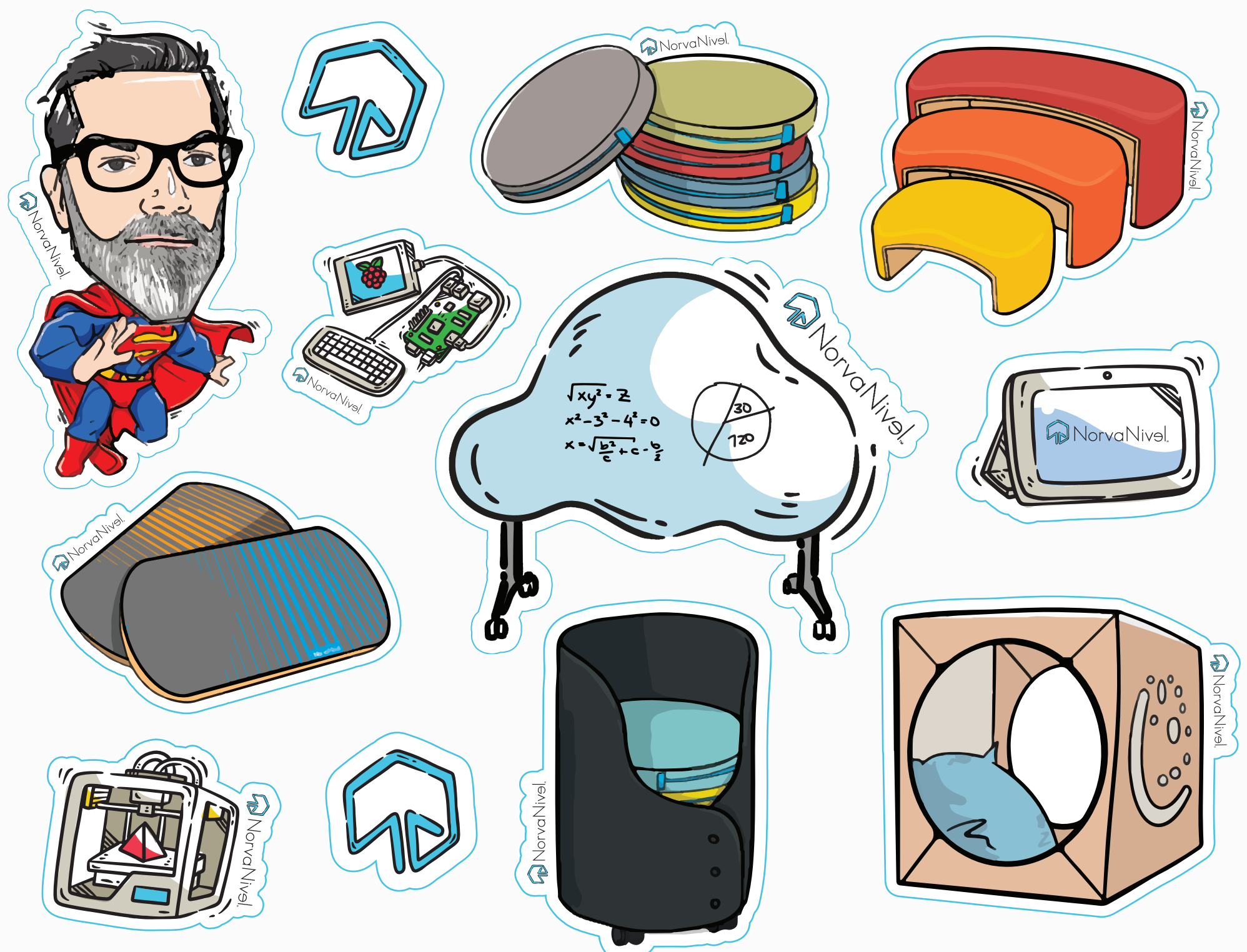
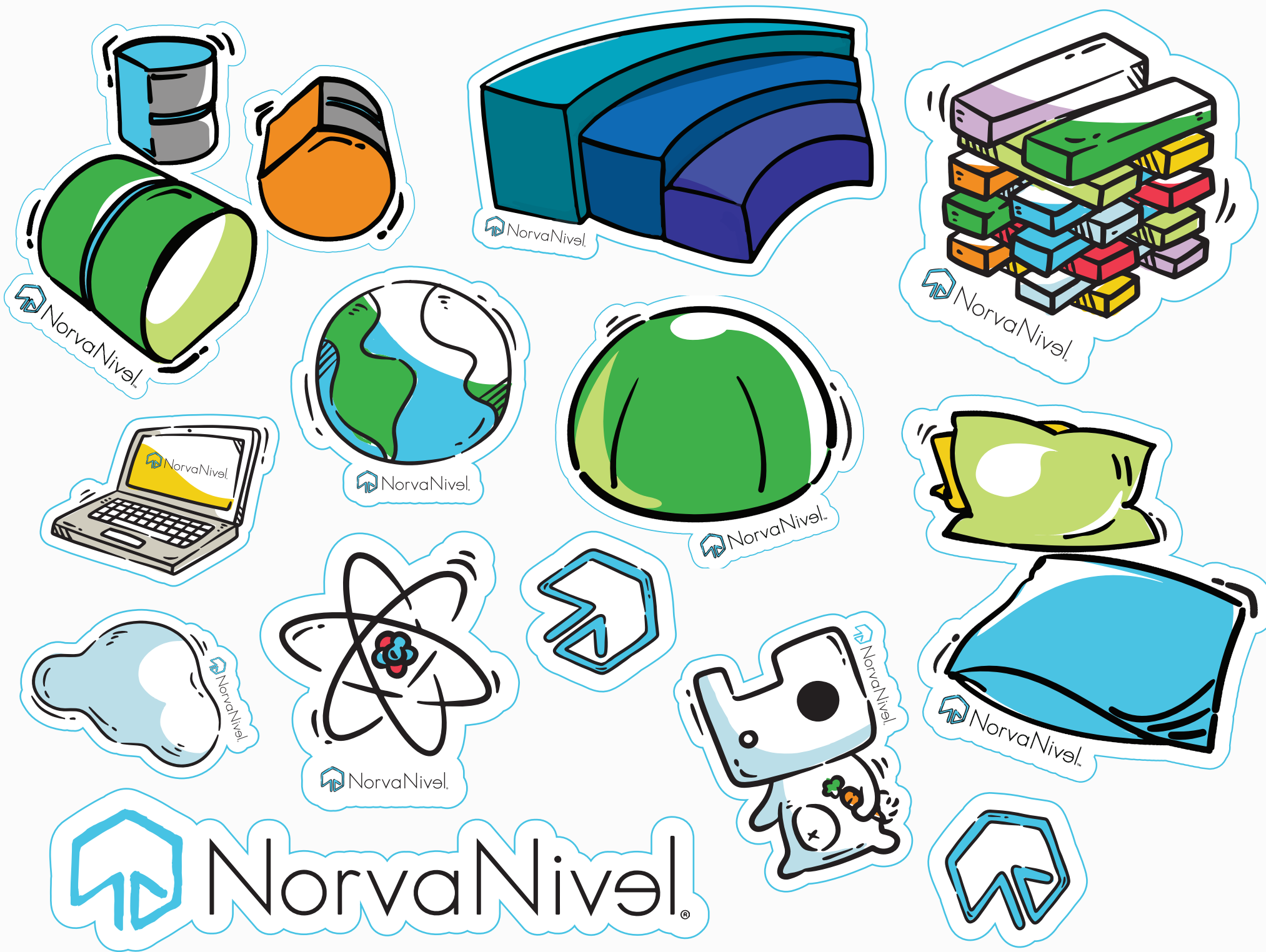

 NorvaNivel®

NorvaNivel[®]
Give them space.

norvanivel.com

972.685.6223 | givethespace@norvanivel.com

This catalog contains images of products that are the subject of patent applications. All rights reserved. ©NorvaNivel 2022

NorvaNivel reserves the right to constantly improve upon our designs, so particular products may change dimensions, components, inclusions, finishes, look different to the catalog images or become unavailable. We will replace those products with something even better!